

NEC

**– Please Read –
Important Cordless Telephone Installation Information**

DS1000/2000 900 MHz Cordless Telephone Installation Tips

- The cordless telephone base unit plugs into a *digital* station port.
- For best results, the base unit should be placed in line-of-site with its handset.
- Cordless telephone range and reception can vary from site to site. Some of the things that may adversely affect range and reception are:
 - Placing the base against or close to a wall (particularly if the wall has metal studs).
 - Positioning the base close to a device that emits Electromagnetic Interference (EMI), such as a TV, radio, computer, fluorescent light, fax machine, or printer.
 - Installing the base close to other 900 Mhz devices, such as Symbol or Telex hand-held inventory devices.
 - Installing the base above a ceiling that uses foil-backed insulation.
 - Installing the base behind a door which can be closed, tinted windows, or one-way glass which will separate the base from the handset.
- Always raise the base unit antenna to its full vertical position.
- When installing more than one cordless in the same site:
 - Be sure the base units are at least 5 feet apart.
 - After installation, change each telephone's channel by pressing **CH** on the handset. This will minimize interference between your cordless telephones.
- The handset must charge 5-8 hours in its charger prior to initial use.
- The Nickel Metal Hydride Rechargeable Battery Pack is recyclable. If you replace a battery pack, always dispose of the old pack along with your other recyclable materials.

Important Upgrade Information

If upgrading from version 3 software prior to 03.10.08 using telephone programming, you must reprogram the options in **1808-IntraMail Subscriber Mailbox Options** after the upgrade.

DS1000

03.14.00

Release Notes

This manual has been developed by NEC America, Inc. It is intended for the use of its customers and service personnel, and should be read in its entirety before attempting to install or program the system. Any comments or suggestions for improving this manual would be appreciated. Forward your remarks to:

NEC America, Inc., Corporate Networks Group

4 Forest Parkway
Shelton, CT 06484
cng.nec.com

Nothing contained in this manual shall be deemed to be, and this manual does not constitute, a warranty of, or representation with respect to, any of the equipment covered. This manual is subject to change without notice and NEC America, Inc. has no obligation to provide any updates or corrections to this manual. Further, NEC America, Inc. also reserves the right, without prior notice, to make changes in equipment design or components as it deems appropriate. No representation is made that this manual is complete or accurate in all respects and NEC America, Inc. shall not be liable for any errors or omissions. In no event shall NEC America, Inc. be liable for any incidental or consequential damages in connection with the use of this manual. This document contains proprietary information that is protected by copyright. All rights are reserved. No part of this document may be photocopied or reproduced without prior written consent of NEC America, Inc.

©2004 by NEC America, Inc. All Rights Reserved.
Printed in U.S.A.

DS1000 Release Notes

DS1000 Release Notes Table of Contents

DS1000 03.10.08 Release Notes

New Features in 03.10.08	1
IntraMail	1
Message Notification	1
How Message Notification Works to Normal Telephone Numbers	2
How Message Notification Works to Digital Pager Numbers	2
Programming	2
Operation	5
Answering a Message Notification Callout to a Telephone	6
Answering a Digital Pager Message Notification Callout	6
Language Selection	7
Spanish Available	7
Programming	7
Operation	8
Regional Defaults	8
Automated Setup	8
Enhanced Features in 03.10.08	9
Caller ID	9
Caller ID Detection Improved	9
Central Office Calls, Placing	9
Store and Forward Introduced	9
Programming	9
Operation	9
Store and Forward with Forced Account Codes ..	10
Extension Hunting	11
UCD Hunting Ignores Extension's Call Forwarding ..	11
IntraMail	11
Answer Schedule Override From Administrator's Mailbox	11
Operation	11

DS1000 Release Notes Table of Contents

Names for Extensions and Trunks	12
Enhanced Name Programming	12
Programming.	12
Operation - User Entered Names	12
Name Programming Operation.	13
Toll Restriction	13
Enhanced Initialization	13
Voice Mail	14
Single Line Can Transfer To Guest Mailbox	14
Caller ID With Return Call In UltraMail	14
Programming.	14
UltraMail Programming	15
Software Corrections in 03.10.08	17
Account Codes	17
Account Codes Store In Speed Dial Bins Do Not	
Appear On SMDR Report	17
Forced And Verified Account Codes Do Not Appear	
On SMDR Report.	17
PC Programming Does Not Correctly Upload Verifiable	
Account Codes	17
Call Forwarding	17
Long Name In Off-Premise Call Forwarding Speed	
Dial Bin Resets System	17
Call Forwarding Off Premise	17
Call Forwarding Key Chooses All Calls.	17
Caller ID	18
Disabling SMDR For Trunk Turns Off Caller ID	18
System Erases Calling Number If Date And Time Not	
Provided	18
Caller ID Logging.	18
Call Without Key Appearance Not Included In	
Extension's Log	18
Door Box.	18
Only Door Box 1 Broadcasts Page	18
Extension Hunting	18
Assigning New Master Number Provides Incorrect	
Message	18
Hunt Type Prompt Displays Incorrect Entry	18
System Resets When Single Line Set Aborts UCD Call	18
Extension Locking	19
SLT User Cannot Unlock Their Extension.	19
Headset Compatibility	19
Phone In Headset Mode Locks Up External Page	19
IntraMail	19
Answer Table Can Route To Subscriber Mailbox	19

DS1000 Release Notes Table of Contents

Automated Attendant Disconnects Remote Logon To Busy Mailbox	19
Conversation Record Resets System When Mailbox Inactive	19
Digits Dialed After UTRF To Ring Group Resets System	19
IntraMail Doesn't Store Messages From Outside Caller . .	20
IntraMail Not Completely Removed From System After De-Installation	20
Message Forward Corrupts Message	20
Multiple Answer Table Assignments Disable MOH Source Entry	20
Remote Logon Leaves Mailbox Busy	20
Remotely Accessing Mailbox Does Not Turn Off MW Lamp	20
Monitor / Silent Monitor	21
Silent Monitor Loses Audio During Voice Over	21
Paging	21
Ringing Line Cannot Control System Relay	21
PC Program	21
Improperly Assigned Door Box Relay Programming . . .	21
Init String Not Sent To Modem After Break	21
PCBs Do Not Function Prior To Break	21
Uploading Program 1807 Overwrites Caller ID Group Definitions	22
Slot Error Messages Sent To Terminal After Display Set Uninstalled	22
Station Message Detail Recording	22
Unanswered Key Ring Call Causes System Reset	22
System Programming Backup and Restore	22
Modem Installed Setting Disables PC Card Functions . .	22
Voice Mail	23
Cannot Assign Voice Mail Port 208	23
SLT Cannot Leave Message For Ringing Operator	23
Cordless Telephone	25
DS1000/2000 900 Mhz Cordless Telephone	25
Cordless Telephone Introduced	25
Programming	25
The Basics	26
Basic Operation	26
Using Your Handset	27
Installation	28
Installing the Base	28
Wall-Mounting the Base	32
Installing the Battery	34

DS1000 Release Notes Table of Contents

Installing the Charger and Charging the Handset	35
Cleaning the Battery Charger Contacts.	35
Wall-Mounting the Charger	36
Installing the Belt Clip	37
Installing Headset P/N 750638 (M145)	38
Installing Headset P/N 750637 (M175)	40
Specifications	42
Parts and Accessories	43
Operation.	44
Barge In.	44
Call Coverage Keys	44
Call Forwarding	44
Call Forwarding Off Premise	44
Call Waiting / Camp On	45
Callback	45
Caller ID	45
Central Office Calls, Answering.	45
Central Office Calls, Placing	45
Conference	46
Directed Call Pickup.	46
Distinctive Ringing.	46
Do Not Disturb Override	47
Extension Hunting	47
Forced Trunk Disconnect	47
Group Call Pickup.	48
Group Ring	48
Hold.	48
Hotline.	48
Intercom	49
Last Number Redial	49
Meet Me Conference.	49
Message Waiting.	49
Microphone Mute	50
Monitor / Silent Monitor.	50
Night Service / Night Ring	50
Off-Hook Signaling	50
Paging	50
Park	50
Prime Line Preference.	51
Privacy Release Groups	51
Programmable Function Keys.	51
Removing Lines and Extensions.	53
Reverse Voice Over	53
Ringling Line Preference	54
Save Number Dialed.	54

DS1000 Release Notes Table of Contents

Speed Dial	54
Split	54
Tandem Trunking	55
Transfer	55
Trunk (Line) Queuing and Callback	56
Voice Mail	56
Voice Over	57
Volume Control	57
Walking Class of Service	58

DS1000 03.10.12 Release Notes

New Features in 03.10.12	61
There are no New Features in this release.	61
Enhanced Features in 03.10.12	62
Message Center	62
Simplified Message Center Access.	62
Software Corrections in 03.10.12	63
Caller ID	63
New DSP Code To Fix Caller ID Related System Reset Problem	63
Caller ID Logging	63
Logs For December Do Not Display Correctly	63
Central Office Calls, Answering.	63
Out-Of-Range Data While Programming Ring Assignments	63
Central Office Calls, Placing	63
Out-Of-Range Data While Programming Trunk Group Access	63
Directory Dialing	64
Unlisted Name Does Not Display Correctly.	64
Distinctive Ringing	64
ASSIGN Soft Key Not Displayed.	64
IntraMail	64
Improved Fax Detection Compatibility	64
Names For Extensions And Trunks	64
Pressing LND Blanks Out Entire Name	64
PC Program.	64
Occasional Reset During Logon	64
System Diagnostics.	65
Out-Of-Range Data Entry Problem While Resetting Extension Ports	65

DS1000 03.11.00 Release Notes

New Features in 03.11.00	67
------------------------------------	----

DS1000 Release Notes Table of Contents

There are no New Features in this release.	67
Enhanced Features in 03.11.00	68
Extension Ringdown.	68
Ringdown to Speed Dial Numbers	68
Selectable Display Messaging	68
Message Scrolling Operation Changed.	68
Software Corrections in 03.11.00	69
IntraMail	69
Conversation Record Limit Resets System.	69
MW Lamp Goes Out On Quick Hangup	69
Pressing L (5) Quickly Can Lock Up Mailbox.	69
UTRF To 0 May Reset System.	69
Language Selection.	69
Additional Translation Corrections.	69

DS1000 03.12.00 Release Notes

New Features in 03.12.00	71
There are no New Features in this release.	71
Enhanced Features in 03.12.00	72
Ringdown Extension.	72
Ringdown to Personal Speed Dial Bin	72
Software Corrections in 03.12.00	73
IntraMail	73
Screened Transfer Recall Loses Queue Elements	73
Message Notification Voice Activity Detector Improved	73
Selectable Display Messaging	73
Cannot Enter Text For Blank Messages	73
Station Message Detail Recording	73
Abbreviated Caller ID Messages	73

DS1000 03.14.00 Release Notes

New Features in 03.14.00	75
There are no New Features in this release.	75
Enhanced Features in 03.14.00	76
There are no Enhanced Features in this release.	76
Software Corrections in 03.14.00	77
Account Codes	77
Account Code/Single Line Problems With MFC Dialing	77
IntraMail	77
Dialing 9 While Leaving A Message Provides Incorrect Voice Prompt	77
Language Selection.	77
Language Corrections for Toll Restriction	77

DS100003.10.08 Release Notes

New Features in 03.10.08

IntraMail

Message Notification

Once activated by the Subscriber Mailbox user, Message Notification dials a telephone number to let the user know when there are new messages in their mailbox. With Message Notification, a subscriber who is out of the office does not have keep calling their mailbox remotely to find out if they have new messages. IntraMail will let them know automatically. Notification can call extensions, local numbers, long distance numbers and digital pagers. When a Subscriber Mailbox user sets up Message Notification, they choose from the following options:

- If Message Notification is enabled or disabled.
(Message Notification can only occur if it is enabled.)
- The time of day Message Notification should begin and end.
(Callouts will only occur between the begin and end times.)
- The type of device to which Message Notification will be calling.
(Message Notification can call a normal telephone number or a digital pager.)
- The telephone or pager service phone number.

Note: To protect your mailbox from unauthorized access, be sure to record a security code for your mailbox before enabling Message Notification.

DS1000 03.10.08 Release Notes

New Features in 03.10.08

How Message Notification Works to Normal Telephone Numbers

1. The subscriber activates Message Notification for their mailbox (see *Operation* below).
2. When the subscriber receives a new message, IntraMail immediately dials the destination that should receive the Message Notification.
3. If the recipient answers, IntraMail plays the notification message (which announces the number of new messages) and asks the recipient to dial 1 to log onto their mailbox. The recipient hears the notification message if:
 - They say “Hello” after answering the callout, or
 - The system receives answer supervision from the telco after the recipient answers the call. (Note that the recipient can skip the announcement by dialing 1 to log onto their mailbox after answering the callout – without saying “Hello”.)
4. Once the recipient logs onto the mailbox, the notification is considered acknowledged and will not reoccur until the subscriber receives new messages.
5. If the recipient doesn’t answer, the system will retry the callout number. After completing the programmed number of callout attempts, Message Notification will stop.
6. Once the notification process begins, a new message does not restart the process if it is already in progress. Once the process ends (e.g., if the message is acknowledged or the maximum number of callout attempts is reached), the next new message will restart the process.

How Message Notification Works to Digital Pager Numbers

1. The subscriber activates Message Notification for their mailbox (see *Operation* below).
2. When subscriber receives a new message, IntraMail immediately dials the pager service.
3. After the pager service answers, IntraMail sends a dial string which causes the pager display to show the subscriber’s mailbox number as well as the number of new messages in the mailbox.
 - The notification is considered acknowledged if the recipient logs onto the mailbox. Notification will not reoccur until the subscriber receives new messages.
 - If the pager service doesn’t answer, IntraMail will retry the callout number. Message Notification may eventually cancel if the callout remains unacknowledged.

Programming

8002-Dial 9 Group

(DIAL 9 GROUP)

Use this option to select the trunk group (90-98) Message Notification will use for callouts. *You must make this assignment and have trunks in the designated group for Message Notification callouts to work.* By default, this option is 90.

8004-Digital Pager Callback Number

(PAGER CALLBACK NUM)

Use this option to set the *Digital Pager Callback Number* portion of the Message Notification callout number for a digital pager. This is the portion of the callout number that is appended to the pager service telephone number. By default, this option is **X*M#**, where:

- **X** is the number of the extension that generated the notification.
- ***** is a visual delimiter (to make the pager display easier to read).
- **M** is the number of new messages in the extension’s mailbox.
- **#** is the digit normally used by the pager service for positive disconnect.

Options

- **Digits** (12 maximum, using 0-9, # and *)
- **M** (Number of messages) (Entered by pressing **MW**)
- **N** (None) (Entered by pressing **CLEAR**)
- **X** (Extension number) (Entered by pressing **ICM**)

IntraMail automatically replaces the **X** command with the number of the extension that initially received the message.

Delay in Dialing Digital Pager Callback Number

(PAGER DIAL DELAY)

Use this option to set the delay (0-99 seconds) that occurs just before IntraMail dials the *Digital Pager Callback Number* portion of the Message Notification callout number for a digital pager. Set this delay so the pager service has enough time to connect to the digital pager before sending the callback number. Your pager service may be able to help you determine the best value for this option (**0-99** seconds). By default, this option is 9 seconds. When placing a digital pager notification, the system:

1. Seizes the trunk specified in **1302-Caller ID Outbound Line/Group**.
2. Dials the user-entered notification number (in **MSG + OP + N**).
3. Waits the **8004-Delay in Dialing Digital Pager Callback Number**.
4. Dials the number entered in **8004-Digital Pager Callback Number**.

The system assumes that the notification number will complete dialing approximately 4 seconds after trunk seizure. This means that, by default, the Digital Pager Callback Number will be dialed into the pager service about 13 seconds after trunk seizure.

Wait Between Digital Pager Callout Attempts

(NTFY PAGER INTVL)

Use this option to set the minimum time (1-255 minutes) between unacknowledged or unanswered digital pager Message Notification callouts. (A subscriber acknowledges a digital pager notification by logging onto their mailbox.) After this interval expires, IntraMail will try the callout again (for up to the number of times set in **8004-Number of Callout Attempts**). By default, this interval is 15 minutes.

If the system dials the callout number and the pager service is busy, it will retry the number in one minute.

Wait Between Non-Pager Callout Attempts

(NTFY N-PGR INTVL)

Use this option to set the minimum time (1-255 minutes) between non-pager Message Notification callouts in which the destination answers, says “Hello,” dials 1 to acknowledge and then enters the wrong security code. By default, this interval is 20 minutes.

Wait Between Busy Non-Pager Callout Attempts

(NTFY BUSY INTVL)

Use this option to set how long IntraMail will wait (1-255 minutes), after it dials a busy non-pager callout destination, before retrying the callout number. The default setting for this option is 15 minutes.

Wait Between RNA Non-Pager Callout Attempts

(NTFY RNA INTVL)

Use this option to set how long IntraMail will wait (1-255 minutes), after it dials an unanswered non-pager callout destination, before retrying the callout number. The default setting for this option is 30 minutes.

There are three types of unanswered non-pager callouts:

- If the callout rings the destination longer than the **8004-Wait for Answer Non-Pager Callout Attempts** option.
- If the destination answers, says “Hello” (or the system detects answer supervision) and then

DS1000 03.10.08 Release Notes

New Features in 03.10.08

hangs up without dialing 1 to log onto their mailbox. This typically happens if someone unfamiliar with notification answers the callout, or if the callout is picked up by an answering machine.

- If the destination answers and then hangs up without saying “Hello.” This typically happens if someone unfamiliar with the notification answers the callout (like the above example), or if the call is picked up by an answering machine which insufficient outgoing message volume.

Wait for Answer Non-Pager Callout Attempts

(NTFY RNA RINGS)

If a non-pager callout rings the destination longer than this option (1-99 rings), IntraMail marks the call as unanswered (Ring No Answer) and hangs up. The default setting for this option is 5 rings.

Number of Callout Attempts

(NTFY CALL ATTEMPTS)

Use this option to set how many times (1-99 attempts) IntraMail will retry an incomplete Message Notification callout. This total includes unacknowledged callouts, callouts to a busy destination, and callouts to an unanswered destination. This option applies to pager and non-pager callouts. The default setting for this option is 5.

Send Pager Callout Until Acknowledged

(RETRY UNTIL ACK)

When this option is enabled (Yes), IntraMail will continue to retry a digital pager Message Notification callout until the notification is acknowledged. If this option is disabled (No), IntraMail will retry a digital pager Message Notification the number of times specified in 8004-Number of Callout Attempts. This option does not apply to Message Notification callouts to telephone numbers. The default setting for this option is No.

A digital pager notification is considered acknowledged when the recipient logs onto the mailbox.

Additional Programming

Check to be sure the following Voice Mail port options do not restrict Message Notification callouts.

- **8002 - Voice Mail Port Options (Part 1): Class of Service**
- **8002 - Voice Mail Port Options (Part 1): Toll Restriction Level (Day)**
- **8002 - Voice Mail Port Options (Part 1): Toll Restriction Level (Night)**
- **8002 - Voice Mail Port Options (Part 1): Dial 9 Group**
- **8002 - Voice Mail Port Options (Part 1): Outgoing Trunk Group Access**
- **8003 - Voice Mail Port Options (Part 2): Trunk Access Type**

Operation

Setting Up Message Notification

Setting Up Message Notification(Sheet 1 of 2) [Super Display Soft Key] - [Keyset Soft Key]			
Log onto Subscriber Mailbox.			
OP (67)	Access the Mailbox Options menu [MBOX OPTS] - [N/A]		
	N (6)	Access the Message Notification Options Menu [NOTIFICATION] + [NTFY]	
		IntraMail plays a summary of your Message Notification settings <ul style="list-style-type: none"> The your telephone display shows your current notification settings (see sample below). The second line of the display is not available on 22- and 32-button display telephones For telephone numbers NOTIFY ON 8AM- 5PM NUM: 12039265400 OR For pager numbers NOTIFY ON 8AM- 5PM PGR: 12039265400	
		O (6)	Turn Message Notification on or off [ON] + [ON] [OFF] + [OFF]
		C (2)	Change your Message Notification setup [CHANGE + CHNG]
			When you see: START TIME
			Enter the hour you want Message Notification to begin <ul style="list-style-type: none"> Enter 2 digits for the hour
		A (2)	Select AM [AM] + [AM]
		P (7)	Select PM [PM] + [PM]
		*	Skip this option without changing your entry [NEXT] + [NEXT]
		#	Back up to the previous level without changing your entry [EXIT] + [EXIT]
			When you see: END TIME
			Enter the hour you want Message Notification to end <ul style="list-style-type: none"> Enter 2 digits for the hour For 24-hour notification, make the End Time the same as the Start Time
		A (2)	Select AM [AM] + [AM]
		P (7)	Select PM [PM] + [PM]
		*	Skip this option without changing your entry [NEXT] + [NEXT]
		#	Back up to the previous level without changing your entry [EXIT] + [EXIT]
			When you see: NOTIFY AT
		N (6)	The notification destination is a telephone number
		D (3)	The notification destination is a digital pager

DS1000 03.10.08 Release Notes

New Features in 03.10.08

Setting Up Message Notification(Sheet 2 of 2) [Super Display Soft Key] - [Keyset Soft Key]					
				*	Skip this option without changing your entry [NEXT] + [NEXT]
				#	Back up to the previous level without changing your entry [EXIT] + [EXIT]
			When you see: NUM		
					Enter the Message Notification callout number (16 digits max) <ul style="list-style-type: none"> • Enter the number exactly as you want the system to dial it (including a leading 1 for toll calls, if required). • If the number you enter is 4 digits or less, it will be an Intercom call. If it is more than 4 digits, it will be an outside call.
				#	Accept the number entered and back up to the previous level [OK] + [OK]
				[CLEAR]	Erase the number you just entered
				*	Skip this option without changing your entry [NEXT] + [NEXT]
				#	Back up to the previous level without changing your entry [EXIT] + [EXIT]
		#	Go back to the Mailbox Options menu [EXIT] + [EXIT]		
	#	Go back to the Main Menu [EXIT] + [EXIT]			
0	Plays Help message				

Answering a Message Notification Callout to a Telephone

To answer a Message Notification to a telephone:

1. Answer the callout at the programmed destination.
If IntraMail doesn't hear your voice (or you don't speak), just go to the next step and dial 1 to proceed.
2. Dial 1 to accept the Message Notification.
OR
hang up to have the Message Notification call back later.
3. When you dial 1, you automatically log onto the subscriber mailbox that left you the Message Notification.
If you don't log onto your mailbox, IntraMail will re-send your notification.

Answering a Digital Pager Message Notification Callout

To answering a Digital Pager notification:

- Operation is automatic.
If you don't call and log onto your mailbox, IntraMail will re-send your pager notification.

DS1000 03.10.08 Release Notes

New Features in 03.10.08

Language Selection

Spanish Available

Language Selection provides telephone displays for soft keys and system programming in English and Spanish. You can select the language for each extension in system programming, or the extension user can choose their language via the soft keys.

In addition, Language Selection also allows to you to print the SMDR header and call type data in English or Spanish. Following is a sample SMDR report in Spanish:

Registro de Detalle de Llamados
05/11/2003 11:47A

Ext	Lin	Numero Marcado	Cuenta	Inicio	Duracion	T
304	03	5551212		11:47:12A	00:00:05	SAL
304	03	5552145		11:42:37A	00:00:08	SAL
102	02	2126657845		11:43:30A	00:00:16	TMB
102	02	MACDONALD MIKE		11:43:30A	00:00:16	TMB
304	02	2126657845		11:44:11A	00:00:08	ENT
304	02	MACDONALD MIKE		11:44:11A	00:00:08	ENT

Programming

0101-Allow Language Programming

Use this option to enable (Y) or disable (N) an extension's ability to set their display language. If enabled, the extension user can access language programming via their soft keys. If disabled, language programming is not allowed. By default, this option is enabled (Y) for Class of Service 1 and disabled (N) for Classes of Service 2-15.

0301-SMDR Language

Use this option to set the language of the SMDR header and the data in the SMDR Call Type (T) field. The options are 0 (English) or 1 (Spanish). Changing this option has no affect on the telephone displays, By default, this option is 0 (English).

When entering data:

- CLEAR** - Sets option to 0 (English)
- CHECK** - Restores option to previous entry
- HOLD** - Stores the entry
- CONF** - Exits the program

1807-Display Language

Use this option to set the language for the telephone display (including system programming). The options are 0 (English) and 1 (Spanish). You can also set this option from the keyset using the soft keys. By default, this option is 0 (English).

When entering data:

- CLEAR** - Sets option to 0 (English)
- CHECK** - Restores option to previous entry
- HOLD** - Stores the entry
- CONF** - Exits the program

DS1000 03.10.08 Release Notes

New Features in 03.10.08

Operation

To select the display language:

From a 22- or 34-Button Display telephone:

1. Press **PGM + MORE + MORE + LANG**.
2. Press one of the following:
 - **ENG** (ING) for English
 - **SPA** (ESP) for Spanish
 - **EXIT** (SAL) to exit without changing the language.
3. Press **CONF** to hang up.

From a Super Display telephone

1. Press **PROGRAM + LANGUAGE**.
2. Press one of the following:
 - **ENGLISH** (INGLES) for English
 - **SPANISH** (ESPANOL) for Spanish
 - **EXIT** to exit without changing the language.
3. Press **EXIT** again to return to idle.

Regional Defaults

Automated Setup

Use 9998-Regional Defaults to switch your system from the US mode (1) to the Latin American mode (2). *Only use this option if your system is installed in Latin America. It is not intended for US applications.* Switching your system to the Latin American mode automatically makes the following changes:

- The default language in programming, SMDR, and all telephone displays is Spanish.
- The Latin American Toll Restriction options are enabled.
- The companding method is switched from Mu-Law to A-Law.

Caller ID

Caller ID Detection Improved

In software version 03.10.08, the Caller ID detection circuit is switched in between the first and second ring burst even if there is noise on the line. In prior software versions, the detection circuit would not be switched in while the noise was occurring. This could result in the Caller ID data being missed by the system.

Central Office Calls, Placing

Store and Forward Introduced

Store and Forward is an alternate method of placing outside calls in which the system stores (“collects”) the digits a user dials, waits for the user to finish dialing, and then redials the digits on the selected trunk. Store and forward provides Intercom dial tone to the caller as soon as they dial a trunk access code or press a loop key, similar to conventional ARS operation. When the user has completed dialing, the system will dial out the call over the connected trunk after 6 seconds or when the user dials #.

Software version 03.10.08 also enables post dialing for Store and Forward calls. After a user dials using Store and Forward, they can manually dial additional digits. The normal post dialing soft keys (such as **AUTO REDIAL [ALND]** for Auto Redial) are also enabled.

Store and Forward does not apply to line keys, Direct Trunk Access, or line dial up (i.e., #9 plus the trunk number).

Programming

1001-Store and Forward

Use this option to enable (Y) or disable (N) Store and Forward for *every trunk* in the trunk group the user will access when they dial a trunk access code or press a loop key. If enabled, the system buffers the user-dialed digits and dials them on the trunk when the user has completed dialing. If disabled, manually dialed digits output on the trunk as the user dials them. *You should enable store and forward for every trunk in accessed trunk group.*

Notes:

- When outdialing the call using DTMF, the system uses the DTMF settings in **0402-Speed Dial DTMF Tone On** and **0402-Speed Dial DTMF Tone Off** (the same as Auto Redial, Last Number Redial, and Save).
- When outdialing the call using Dial Pulse, the system uses the Dial Pulse settings in **0402-DP Make Timer**, **0402-DP Break Timer**, and **0402-DP Interdigit Timer**.
- The 6 second interval the system waits before dialing the Store and Forward call is determined by the setting of **0401-Intercom Inter-digit Time**.

Operation

To place an outside call using Store and Forward:

1. Press **ICM** and dial **9** (or optionally 90-98).

DS1000 03.10.08 Release Notes

Enhanced Features in 03.10.08

OR

Press Switched Loop key + Dial the trunk group number (0-8).

OR

Press Fixed Loop key.

Listen for Intercom dial tone.

2. Dial the outside telephone number.
3. When you have completed dialing, wait 6 seconds or dial #.
The stored number dials out.

Store and Forward with Forced Account Codes

You can use Account Codes if your system has Store and Forward enabled (see *Operation* below). If you have Forced Account Codes enabled, to prevent users from bypassing Forced Account Codes consider making the following programming changes:

- **0101-Direct Trunk Access** = N (disabled)
- **1802-Line Dial Up** = N (disabled)
- **1802-Key Access to Outbound Lines** = N (disabled)

Operation

To place an outside call when both Store and Forward and Account Codes are enabled:

If the system has Forced Account Codes enabled for Toll Calls Only, place local calls normally (e.g., 9 + Dial outside number), without using the following procedure.

With Forced Account Codes for Toll Calls Only, you do not have to enter an Account Code for local calls. Just dial the call normally.

1. Press **ICM** and dial **9** (or optionally 90-98).
OR
Press Switched Loop key + Dial the trunk group number (0-8).
OR
Press Fixed Loop key.
Listen for Intercom dial tone.
2. Dial the outside telephone number.
3. Wait for three beeps (Forced Account Codes only).
OR
Press the **ACCT (ACCT CODE)** soft key.
OR
Press your Account Code key.
4. Enter your Account Code.
5. Wait 6 seconds.
OR
Press the **ACCT (ACCT CODE)** soft key.
OR
Press your Account Code key.
OR
Dial #.

Extension Hunting

UCD Hunting Ignores Extension's Call Forwarding

Calls to a UCD Hunting Group *will not* follow Call Forwarding at a group member's extension. However, calls directed to the group member's extension (such as DILs and transferred calls) *will* follow the Call Forwarding set up at the extension. In prior software versions, Call Forwarding at a group member's extension would pull a UCD call out of the group and send it to the programmed forwarding destination. This type of UCD hunting disruption will no longer occur.

IntraMail

Answer Schedule Override From Administrator's Mailbox

You can set up Answer Schedule Override from the System Administrator's Mailbox as well as from system programming. This allows remote access to Answer Schedule Override when it is not convenient to use system programming. In prior software versions, Answer Schedule Override was only available from system programming.

Operation

Enabling Answer Schedule Override [Super Display Soft Key] - [Keyset Soft Key]				
Log onto System Administrator's Mailbox				
O (6)	Access Answer Schedule Override [MBOX OPTS] - [N/A]			
1-8	Enter the number of the Answer Table you want to override <ul style="list-style-type: none"> • You go to the Answer Schedule Override Menu 			
O (6)	Turn Answer Schedule Override on or off [ON] - [ON] [OFF] - [OFF]			
C (2)	Select the Override Mailbox [MAILBOX] - [MBOX]			
	Enter the Override Mailbox number <ul style="list-style-type: none"> • The Override Mailbox can be an Announcement, Call Routing, Subscriber, or Master Mailbox. 			
			#	Go back to the Answer Schedule Override Menu without entering an Override Mailbox [EXIT] - [EXIT]
0	Plays Answer Schedule Override Menu Help message			
#	Go back to the System Administrator Menu [EXIT] - [EXIT]			
X (9)	Exits your mailbox			
		X (9)	Exits your mailbox. [EXIT] - [EXIT]	
		#	Returns to your mailbox. [RETURN] - [RETN]	
#	Go back to the Main Menu [EXIT] + [EXIT]			
0	Plays Help message			

DS1000 03.10.08 Release Notes

Enhanced Features in 03.10.08

Names for Extensions and Trunks

Enhanced Name Programming

Name programming operation is enhanced to be consistent with name entry methods currently used by many cellular telephones. See *Name Programming Operation* below. The programs affected by this enhancement are:

- **0302-Company Name**
- **0510-Name**
- **0511-Name**
- **0801-Selectable Display Messages**
- **1001-Name**
- **1101-System Speed Dial Name**
- **1702-Personal Speed Dial Name**
- **1801-Extension Name**

Programming

0101-Allow Name Programming

Use this option to enable (Y) or disable (N) name programming at an extension. If enabled, the extension user can access name programming via their soft keys. If disabled, name programming is not allowed. By default, this option is enabled (Y) for Class of Service 1 and disabled (N) for Classes of Service 2-15.

Operation - User Entered Names

A display keyset user can program the name for their extension:

To program your extension's name:

If you have Access Level 4 or 5, go to "To program a name for a co-worker's extension" below.

1. At a 22- or 34-Button Display Telephone:
Press **PGM + MORE + MORE + NAME**.
At a Super Display Telephone:
Press **PROGRAM + NAME**.
2. Follow the instructions in *Name Programming Operation* below.
3. Press **HOLD + CONF** to exit.

A display keyset user with Access Level 4 and 5 can program the name for a co-worker's extension, their own extension, a Ring Group, or a UCD Group.

To program a name for a co-worker's extension:

You must have Access Level 4 or 5 to use this procedure.

1. At a 22- or 34-Button Display Telephone:
Press **PGM + MORE + MORE + NAME**.
At a Super Display Telephone:
Press **PROGRAM + NAME**.
2. When you see: **EXT:300**, enter the number of the extension you want to program + **HOLD**.
You can optionally enter a Ring Group or UCD Group master number to program the name of the associated group.
3. Follow the instructions in *Name Programming Operation* below.
4. Press **HOLD + CONF** to exit.

DS1000 03.10.08 Release Notes

Enhanced Features in 03.10.08

Name Programming Operation

Name Programming									
Key	Press a key the indicated number of times for desired character								
	1 Time	2 Times	3 Times	4 Times	5 Times	6 Times	7 Times	8 Times	9 Times
1	&	-	/	‘	1				
2	A	B	C	a	b	c	2		
3	D	E	F	d	e	f	3		
4	G	H	I	g	h	i	4		
5	J	K	L	j	k	l	5		
6	M	N	O	m	n	o	6		
7	P	Q	R	S	p	q	r	s	7
8	T	U	V	t	u	v	8		
9	W	X	Y	Z	w	x	y	z	9
0	space	:	0						
#	Not used								
*	Not used								
After selecting a letter, press a key for another letter or wait 2 seconds for the cursor to automatically advance.									
Additional Name Programming Options									
HOLD	Save name. In system programming, HOLD saves and exits name programming.								
CONF	Exit name programming without saving name.								
VOL Up	Scroll the cursor to the left.								
VOL Dn	Scroll the cursor to the right.								
MW	Put the cursor after the last entry.								
LND	Delete the character under the cursor.								
FLASH	Delete the character to the right of the cursor.								
CLEAR	Clear the entire entry.								
CHECK	Restore the previous entry,								

Toll Restriction

Enhanced Initialization

Program **0601-Configure Toll Level Options** allows you to initialize Toll Restriction for US or International applications. You should always initialize Toll Restriction for the US. International Toll Restriction provides different tables and options that do not apply to systems installed in North America.

DS1000 03.10.08 Release Notes

Enhanced Features in 03.10.08

Programming

0601 - Configure Toll Level Options (Initialization Options)			
ICM + ##* + Password (372000) + HOLD + 0601 + HOLD			
PROG-P / INIT-I?			
I (4)	Initialize Toll Restriction		
ARE YOU SURE? (Y/N)			
	Y (9)	Proceed with initialization	
		1 - U.S / 2 - INTL	Select the type of Toll Restriction initialization (US or International)
		1 + HOLD	Initialize Toll Restriction for US applications (recommended)
		2 + HOLD	Initialize Toll Restriction for International applications (<i>not for US installations</i>)
	N (6)	Back up without initializing	
P (7)	Program Toll Restriction (after initializing)		

Voice Mail

Single Line Can Transfer To Guest Mailbox

A single line extension user can Transfer an outside call to a Guest Mailbox (i.e., a Subscriber Mailbox that does not have an associated physical extension). This capability was not allowed in software versions prior to 03.10.08.

To Transfer an outside call to a Guest Mailbox (from a single line extension):

1. Hookflash + Dial *8.
2. Dial Guest Mailbox number.
3. Hang up.

Caller ID With Return Call In UltraMail

The system fully supports UltraMail Caller ID with Return Call. If Caller ID is enabled in the system, a subscriber can press **MC** (62) while listening to a message and automatically return the call without knowing the caller's number. UltraMail sends the Caller ID digits to the system, which then analyzes the digits according to the Caller ID Logging programming. This allows the system to distinguish between local and long distance calls, process 10-digit local calling (if required), and handle any toll calls within the home area code (as well as local calls within an adjacent area code).

Note: The system requires that the telco provide 10-digit Caller ID number data.

Programming

1001-Caller ID

Enable Caller ID for each trunk that receives Caller ID from the telco. The options are 1 (DSP), 2 (daughter board in DS2000 only), and 0 (disabled). By default, this option is disabled (0).

1001-Voice Mail Caller ID

Enable (Y) this option so the system will send the Caller ID data on a trunk to voice mail. If disabled, any trunk call answered by voice mail will not contain the Caller ID Data required by the

DS1000 03.10.08 Release Notes

Enhanced Features in 03.10.08

Caller ID with Return Call feature. By default, this option is enabled (Y).

1302-10 Digit Local Calls

Use this option to indicate if the system is installed in an area that uses 10-digit local calling. Enable (Y) this option if the system is in a 10-digit local calling area. Disable (N) this option if the system is not in a 10-digit local calling area.

1303-Home area (HNPA) Codes

Use this option to specify your system's home area codes. This is the area code in which the system is installed. *You must make an assignment in this program so that the system can properly process Caller ID with Return Call callbacks.* By default, there are no home area codes defined.

1304-Home Area (HNPA) Exception List

Use this option to identify which (if any) calls within your home area code are toll calls. You can set up the Exception List table as a local table (L) or a toll table (T). By default, the HNPA Exception List is a toll table with no entries. (This means that the system outdials *all* calls within the home area code without the leading 1.)

1305-Foreign Area (FNPA) Exception List

If your dialing area has calls in an adjacent area code that are local calls, enter those codes in this table. If the system finds a code in the table, it will dial it as 10-digit (without the leading 1). If the system does not find the code, it will outdial it as 1 + 10-digit. By default, the FNPA table is a local table with no entries. This means that all FNPA codes are dialed as toll calls.

8002-Toll Level Day

Use this option to set the toll level of the voice mail ports during the day. If the number Caller ID with Return Call is attempting to dial is prevented by the voice mail port's toll level, the call will not go through. By default, this option is 0 (unrestricted).

8002-Toll Level Night

Use this option to set the toll level of the voice mail ports during the night. If the number Caller ID with Return Call is attempting to dial is prevented by the voice mail port's toll level, the call will not go through. By default, this option is 0 (unrestricted).

8002-Dial 9 Group

Use this option to specify the dial-9 group for voice mail ports. When a voice mail port dials 9, it uses the trunk group you select in this option. By default, option is 90.

8002-Outgoing Trunk Group Access

For the trunk group specified in **8002-Dial 9 Group** above, be sure to enable (y) outgoing access in this option. By default, this option is enabled (Y) for all trunk groups.

UltraMail Programming

- *Customize: Mailbox Options: Subscriber: [Message Notification] Options: Message Notification/Fax Callbacks*
 - Enable (check) this option for each subscriber that should be able to use Caller ID with Return Call.
- *Customize: Mailbox Options: Subscriber: [Message Notification] Options: Long Distance Calls*
 - Select *Yes* to allow UltraMail to place unrestricted Caller ID with Return Call callbacks.
 - OR
 - Select *Some* and make entries in *Area Code Entry* to permit Caller ID with Return Call call-

DS1000 03.10.08 Release Notes

Enhanced Features in 03.10.08

backs only to the specified area codes.

- *Customize: Tenant Options: Access Digits before Long Distance Callout*
 - Use this option to enter the dialing prefix that enables UltraMail to seize an outside line for callouts. You should leave this option at its default value (9P).

Account Codes

Account Codes Store In Speed Dial Bins Do Not Appear On SMDR Report

In 03.**.** software versions prior to 03.10.08, 0201-Enable Account Codes in Speed Dial did not function correctly. Account Codes stored in a bin key would not print on the SMDR report. This is now corrected.

Forced And Verified Account Codes Do Not Appear On SMDR Report

Software version 03.10.08 corrects the following problem in prior software versions that would prevent Account Codes from printing on the SMDR report.

- In **0101-Forced Account Codes**, enter Y.
- In **0101-Verify Account Codes**, enter Y.
- In **0201-# Key to Enter Account Codes**, enter Y.
- In **1201-Verified Account Codes Table**, enter some Account Codes into the table.
- User places a call using the following steps:
 - Press a line key
 - Dial an Account Code + #
 - Dial outside number.

In prior software versions, the Account Code would not print on the SMDR report after the user hung up.

PC Programming Does Not Correctly Upload Verifiable Account Codes

Software version 03.10.08 corrects a problem when using PC Program option *Programming: System: Accounts* to enter **1201-Verified Account Codes** data. In prior software versions, the data uploaded by the PC Program could not be used by the system. This is now corrected.

Call Forwarding

Long Name In Off-Premise Call Forwarding Speed Dial Bin Resets System

If software versions 02.11.00 and above, the system will eventually reset if the user selects an existing Speed Dial bin for Call Forwarding Off Premise which has a name longer than 10 characters. This problem is corrected in software version 03.10.08.

Call Forwarding Off Premise

Call Forwarding Key Chooses All Calls

If an extension user implements Call Forwarding Off Premise, they can use their Call Forwarding key (if programmed) to turn forwarding off and on. In prior software versions, the following would occur:

1. Set up Call Forwarding Off Premise for trunk calls only.
2. Press the Call Forwarding key. After 6 seconds, Call Forwarding Off Premise will cancel.
3. Press the Call Forwarding key again. After 6 seconds, Call Forwarding Off Premise will again be enabled *but for all calls* (not just trunk calls).

DS1000 03.10.08 Release Notes

Software Corrections in 03.10.08

Caller ID

Disabling SMDR For Trunk Turns Off Caller ID

Software version 03.10.08 corrects a problem in prior software versions in which disabling SMDR for a trunk in **1001-Print SMDR** would also turn off Caller ID for that trunk.

System Erases Calling Number If Date And Time Not Provided

If the connected telco does not provide the date and time along with the Caller ID record, the system substitutes its own date and time. In prior software versions, this substitution would overwrite the calling party's number (i.e., the call record would be displayed without the calling party's number).

Caller ID Logging

Call Without Key Appearance Not Included In Extension's Log

In prior software versions, Caller ID Logging would not store the call data if the extension did not have a key appearance (line or loop key) for the call. This is corrected in software version 03.10.08.

Door Box

Only Door Box 1 Broadcasts Page

If both Analog Door Boxes are in the same page zone, a page to that zone will broadcast out of the speaker in each Door Box. In prior software versions, the page would broadcast only out of speaker in Door Box 1.

Extension Hunting

Assigning New Master Number Provides Incorrect Message

Software version 03.10.08 corrects the following problem that occurred in prior 03.**.** software versions when assigning new UCD Hunting group master numbers.

1. Enter program 0510.
2. Select a group and enter 799 for the new master number (assuming that 799 is not used).
3. Press **HOLD**, then **VOL UP** to scroll to the next option. The display shows: **EXT ALREADY EXISTS** (even though the number was not previously used).

Hunt Type Prompt Displays Incorrect Entry

Software version 03.10.08 corrects a problem in prior 03.10.** versions in which program **1807-Hunt Type** would not display the correct type after entry. The program would function correctly, but the type would display incorrectly. For example, the entry for extension 300 would always display **NONE**, while the entry for extension 301 would always display **TRUNK RNA**.

System Resets When Single Line Set Aborts UCD Call

In prior software versions, a system reset would occur under the following conditions:

- Single line extension user (or Voice Mail/IntraMail port) dials a UCD master number.
- While the call is ringing a UCD member, the single line user hookflashes and dials a busy extension.

DS1000 03.10.08 Release Notes

Software Corrections in 03.10.08

This reset does not occur in software version 03.10.08.

Extension Locking

SLT User Cannot Unlock Their Extension

In software versions prior to 03.10.08, a single line extension user could dial **##5** to lock their extension but they could not unlock it. This is corrected.

Headset Compatibility

Phone In Headset Mode Locks Up External Page

Software version 03.10.08 corrects the following problem that in which a headset user could lock up External Page:

1. Enable the Headset mode at a keyset (e.g., extension 304).
2. Answer a trunk call at 304 on line 1 by pressing the line key 1.
3. Press **HOLD**, but do not press **SPK**.
4. Press a Speed Dial bin key that is set up to dial Intercom code *11.
5. Answer a second trunk call at 304 on line 2 by pressing the line 2 line key.

Extension 304 is left talking to line 2 and being broadcast over External Paging. If the extension 304 user presses the Speed Dial key for the paging code (*11), they see **PAGE BUSY** in the display (even after the outside calls are disconnected).

IntraMail

Answer Table Can Route To Subscriber Mailbox

When setting up an IntraMail Answer Table, the **8007-Routing Mailbox Number** entry can be a Call Routing, Announcement, or Subscriber Mailbox. When assigned as a Subscriber Mailbox, an outside call will immediately route to the Subscriber Mailbox so the caller can leave a message. In prior software versions, you could make the program entry but the call would not route to the Subscriber Mailbox.

Automated Attendant Disconnects Remote Logon To Busy Mailbox

In 03.**.** software versions prior to 03.10.08, IntraMail would disconnect an Automated Attendant caller that attempted to log on to a busy Subscriber Mailbox (using # + mailbox number). In version 03.10.08, a caller attempting to log onto a busy Subscriber Mailbox hears “*That mailbox is busy*” and is sent immediately back to the Automated Attendant.

Conversation Record Resets System When Mailbox Inactive

In an extension has Conversation Record enabled in **0101-Conversation Record**, and their mailbox inactive in **1808-Mailbox Active**, they will not have a **RECORD (REC)** soft key. In prior software versions, the **RECORD (REC)** soft key was active and pressing the key while their mailbox was inactive would reset the system.

Digits Dialed After UTRF To Ring Group Resets System

Software version 03.10.08 corrects the following problem that in prior software versions could cause a system reset.

DS1000 03.10.08 Release Notes

Software Corrections in 03.10.08

- In **8008-IntraMail Dial Action Tables**, set up a digit to be a UTRF to a Ring Group or UCD Hunting Group master number (e.g., 600).
- After IntraMail answers, the caller dials the digit to reach the Ring or UCD Hunting Group.
- After the caller hears, “Please hold a moment,” they dial additional digits. The system could then reset.

IntraMail Doesn’t Store Messages From Outside Caller

Software version 03.10.08 corrects a problem in prior 03.**.** versions in which an outside caller leaving a message in a Subscriber Mailbox would not be recorded. The extension’s **VM** soft key would update and the message count would be correct, but the subscriber could not listen to the message.

IntraMail Not Completely Removed From System After De-Installation

If you power down the system and remove the IntraMail PCB, IntraMail will be completely removed from programming when the system restarts. In prior software versions, **8001-Voice Mail Type** still showed *INTRAMAIL* as the programmed option even after the PCB was removed and the system restarted.

Message Forward Corrupts Message

Software version 03.10.08 corrects a problem with Message Forward that would corrupt the forwarded message. In prior 03.**.** software versions, the following would occur:

1. Subscriber listens to a message and dials **MF** (63) before the message completes.
2. Subscriber then enters 300, presses **CONTINUE (CONT)** twice, **EXIT** twice, then **SPK** to hang up.
3. The following occurs:
 - There is no flashing **MW** LED at extension 300 indicating the new message.
 - If the subscriber leaves another message at extension 300, the first message (i.e., the forwarded message) will be corrupt.

Multiple Answer Table Assignments Disable MOH Source Entry

Software version 03.10.08 corrects a problem in prior versions in which assigning multiple Answer Tables to trunks in **1003-Answer Table** would disable the ability to make **1003-MOH Source** assignments.

Remote Logon Leaves Mailbox Busy

Software version 03.10.08 corrects a problem in prior 03.**.** versions that would leave a Subscriber Mailbox busy after a remote logon through the Automated Attendant. The following would occur:

1. An Automated Attendant caller dialed # plus a mailbox number to remotely log onto a Subscriber Mailbox.
2. Caller dialed 9 to exit the mailbox, then * to return to the Automated Attendant.
3. Caller immediately dialed # plus the mailbox number to log back into the same Subscriber Mailbox. IntraMail would prevent the logon and the caller would hear, “*That mailbox is busy.*”

Remotely Accessing Mailbox Does Not Turn Off MW Lamp

In versions of 03.**.** software prior to 03.10.08, a subscriber remotely accessing their mailbox and deleting new messages would not update (turn off) the **MW** LED on their extension. This was typically done by calling into the Automated Attendant, dialing #, then dialing the mailbox number to log onto their mailbox. In software version 03.10.08, the system will properly update an extension’s **MW** LED when the subscriber listens to their messages remotely.

DS1000 03.10.08 Release Notes

Software Corrections in 03.10.08

Monitor / Silent Monitor

Silent Monitor Loses Audio During Voice Over

If an extension is being Silent Monitored by another extension, a third extension cannot call them using Voice Over. In prior software versions, the Voice Over connection would be set up without a speech path.

Paging

Ringling Line Cannot Control System Relay

The system relay(s) can activate whenever a trunk call rings into the system (depending on programming). In prior versions of 03.**.** software, you could program the relay(s) to activate for incoming trunk calls but they would not function.

PC Program

Improperly Assigned Door Box Relay Programming

Software version 03.10.08 corrects the following DS1000 Door Box relay assignment problem that occurred in PC program versions 01.00.30 and earlier:

- In telephone programming **1801-Relay Owner** for extension 324, assign the relay to DOOR1 (1).
- In telephone programming **1801-Relay Owner** for extension 325, assign the relay to DOOR2 (2).
- Connect to the system using the PC Program and download all system data.
- In *Programming: Stations: Setup: Door Box*, the relay assignments are reversed. Station 25 (extension 324) has relay assignment DOOR2; station 26 (extension 325) has relay assignment DOOR1.

PC Program version above 01.00.30 is also required to fix this problem.

Init String Not Sent To Modem After Break

When **0301-Modem Installed** is enabled (Y), the system outputs the initialization string set in the PC Program screen *Programming: System: Setup* under the following conditions:

- When the system is powered up or reset (while the modem is connected).
- If the string is changed in the PC Program (while the modem is connected). The string is sent after the PC Program session ends.
- If the modem is plugged into the serial port and powered up.
- Any time the modem is connected and the **0301-CPU Baud Rate** or **0301-Modem Installed** options are changed.
- The PC Program user clicks the *Break Connection* button (and the modem is connected).

In software versions of 03.**.** prior to 03.10.08, the system would not send the string to the connected modem after the user clicked the *Break Connection* button.

PCBs Do Not Function Prior To Break

When on-line, the following two methods of inserting PCBs will work correctly.

Method A

1. Go on-line in a default system with no PCBs installed (other than the CPU).

DS1000 03.10.08 Release Notes

Software Corrections in 03.10.08

2. Use *Programming: Ports* to set up a PCB.
3. Upload the change to the system.
4. Plug in the PCB. It will function correctly.

Method B

1. Go on-line in a default system with no PCBs installed (other than the CPU).
2. Plug in a PCB. (It will be temporarily inoperable.)
3. Use *Programming: Ports* to set up a PCB.
4. Upload the change to the system. The PCB will function correctly.

In prior 03.**.** versions, Method B would not work. The PCB would not function until you clicked the *BREAK* button.

Uploading Program 1807 Overwrites Caller ID Group Definitions

In prior 03.**.** software versions, using the PC Program to upload program **1807-Extension Options (Part 2)** data would overwrite the Caller ID Group configurations in **1301-Caller ID Group Configuration**. In software version 03.10.08, this no longer occurs.

Slot Error Messages Sent To Terminal After Display Set Uninstalled

Software version 03.10.08 corrects the following PC Program error:

1. Connect a display telephone to an installed station port.
2. Use *Programming: Ports* to uninstall the station's PCB.
3. The system continually sends error messages to the terminal. In addition, a system reset may occur.

Station Message Detail Recording

Unanswered Key Ring Call Causes System Reset

Software version 03.10.08 corrects a problem in prior 03.**.** versions in which an unanswered Key Ring call would reset the system when SMDR was enabled (**0301-SMDR Port = 1**).

System Programming Backup and Restore

Modem Installed Setting Disables PC Card Functions

Software version 03.10.08 corrects the following error when setting up the external modem:

- In **0301-Modem Installed**, enter Y.
- If the modem is off-line or not installed (i.e., Carrier Detect is inactive), the following programs do not work:
 - **9906-Database Save**
 - **9907-Database Load**
 - **9908-PC Card Erase Utility**

Voice Mail

Cannot Assign Voice Mail Port 208

Software version 03.10.08 corrects a problem in prior 03.**.** versions in which program **9902-Set Up Stations** could not assign Voice Mail station number 208.

SLT Cannot Leave Message For Ringing Operator

A single line telephone user can place an Intercom call to an operator and dial 8 to leave a message, regardless of whether the call rings or voice-announces the operator. In prior software versions, a single line user could dial 8 to leave a message only if the operator answered the call voice-announced. If the call rang the Operator Call Key, the single line user could not dial 8 to leave a message.

DS1000 03.10.08 Release Notes

Software Corrections in 03.10.08

– This page intentionally left blank –

DS1000/2000 900 Mhz Cordless Telephone

Cordless Telephone Introduced

The DS1000/2000 900 Mhz Cordless Telephone (P/N 80683) is a 900 Mhz digital narrow band FM cordless telephone that provides mobility, flexibility and convenience for those who spend much of the workday away from their desk. Fully integrated with the DS1000/2000 system, DS1000/2000 900 Mhz Cordless Telephone offers many standard features such as Call Forwarding, Call Coverage, Hotline, and Voice Mail. Complemented by 4 fully programmable function keys (with LEDs), the DS1000/2000 900 Mhz Cordless Telephone achieves a whole new level of convenience and mobility. An easy-to-read 16-character by 2-line LCD display (with four status icons), volume controls, a rechargeable Nickel Metal Hydride Battery Pack, and a handy belt clip round out the elegant and affordable DS1000/2000 900 Mhz Cordless Telephone.



The DS1000/2000 900 Mhz Cordless Telephone auto-IDs in **1801-Extension Circuit Type** with circuit type 50. No additional programming is required for basic feature operation.

Programming

1802-Ring Down Destination

For the cordless telephone extension number, use this option to designate the extension associated with the base unit *Desk* button. By default, there is no entry for this option.

DS1000 03.10.08 Release Notes

Cordless Telephone

The Basics

Basic Operation

Answering Calls

- *Outside calls:* Ring with 2 short rings followed by a long ring.
- *Intercom calls:* Ring with 1 long ring.
- *To answer a call:* Press **TALK** or the flashing line key.
If your handset is in the charger, lifting the handset answers the incoming call.

Placing Calls

- *Intercom calls:* Press **TALK** + Dial co-worker's extension or *8 for Voice Mail.
- *Outside calls:* Press **TALK** + Dial trunk access code + Dial outside number, or Press line key + Dial outside number

Hanging Up

- Press **TALK** or place the handset in the charger.

Changing Channels

If the installation site has more than one DS1000/2000 900 Mhz Cordless Telephone, set up each telephone to operate on its own channel.

- While on a call, press **CH**.
*TALK flashes briefly while the handset changes channels. There are 30 channels max.
If you select a channel that is already in use, you see **SYSTEM BUSY**.*

Standby Mode

- When the handset is out of the charger, it will go into Standby Mode after about 5 minutes. Standby mode blanks the display to conserve power.
- Placing or answering a call automatically cancels Standby Mode.

Traveling Out Of Range

- If you try to place a call while out of range (beyond the range of your handset):
 - **ACQUIRING LINK** flashes in your display
 - You hear five quick beeps
 - **NO SERVICE** flashes in your display.
- If you travel out of range while on a call:
 - You hear five quick beeps.
 - Your handset goes into standby mode.
 - The call disconnects.

Using the Base *Cordless* and *Desk* Buttons

- *While on a call at your cordless handset:* Press **Desk** to transfer the call to your desk extension.
- *While on a call at your desk extension:* Press **Cordless** to transfer the call to your cordless handset.
- *While idle at your cordless handset:* Press **Desk** to call your desk extension on the Intercom.
- *While idle at your desk extension:* Press **Cordless** to beep (locate) for cordless handset.

Low Battery

If the **LOW** icon displays:

- If on a call, press **TALK** to hang up as soon as possible so your call is not interrupted.
- Recharge or replace the battery before placing or answering another call.

DS1000 03.10.08 Release Notes

Cordless Telephone

Using Your Handset

Ringer

- On when ring is turned off

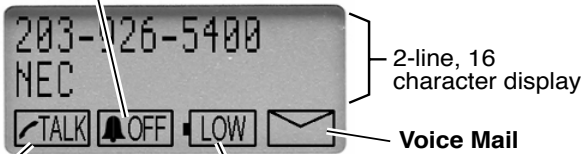

Talk

- Off while idle
- On while on a call
- Flashes while microphone muted

Battery

- On when battery is low

Voice Mail

- On if you have a Voice Mail message or Message Waiting.
- Dial *8 to respond



Ring Volume

- While idle, press to select ring type or vibrate
- While on a call, press to change handset receiving volume

Ring On/Off Mute

- While on a call, press to mute microphone
- While idle, press and hold 5 seconds to turn ringer on or off



Headset jack

While on a call

Press to transfer call to handset

Press to transfer call to desk extension



While idle

Press to locate (beep) handset

Press to call desk extension

Conference

- While on a call, press CONF to set up a conference

Hold

- Press HOLD to put your call on hold

Talk

- While idle, Press TALK for Intercom dial tone
- While busy, press TALK to hang up

Last Number Redial

- Press REDIAL to redial your last call

Note: **ACQUIRING LINK** means your handset is setting up a connection with the base



Transfer

- TRANSFER + Extension transfers call to a co-worker
- TRANSFER + 700 transfers call to Voice Mail

Channel

- Press CH to change channels if you hear interference
- 30 separate channels

Programmable Keys

- Line keys 1-4 by default
- Can optionally be programmed for other features

Microphone
Picks up your voice

DS1000 03.10.08 Release Notes

Cordless Telephone

Installation

Installing the Base

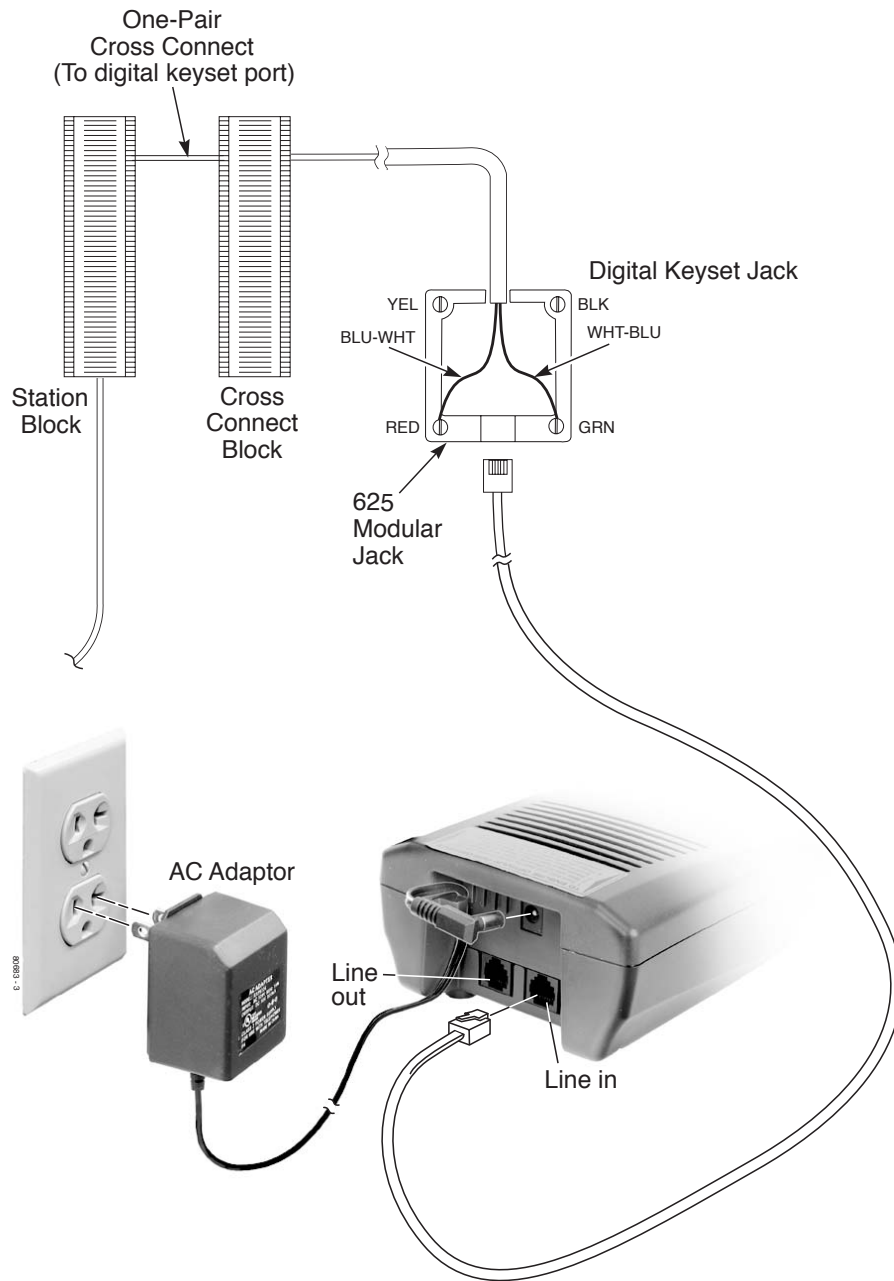

DS1000 03.10.08 Release Notes

Cordless Telephone

To connect the base to the DS1000/2000 system:

Be sure to review the guidelines and illustrations on the next page.

1. Install a modular jack within 6 feet of the base and within 6 feet of an available standard (NEMA 5-15R) 120 VAC outlet.
2. Run a single pair of 24 AWG station cable from the cross-connect block to the modular jack.
3. Terminate the station cable **WHT/BLU - BLU/WHT** leads to the **RED** and **GRN** lugs on the modular jack.
4. Back at the main equipment location, run one pair of cross-connect wire between an *available digital station port* pins on the extension block and cross-connect block to complete the installation.
5. Install bridging clips as required.
6. Plug one end of a modular line cord into the base **LINE IN** jack; plug the other end of the line cord into the modular jack.

The DS1000/2000 900 Mhz Cordless Telephone auto-IDs in 1801-Extension Circuit Type with circuit type 50. No additional programming is required for basic feature operation.

To connect the AC Adaptor to the base:

1. Run the AC adaptor cord under the strain relief on the back of the base as shown.
2. Plug the AC adaptor into AC outlet.
3. Be sure the base antenna is in the vertical position.

Checking the Base LEDs

Normal Operation

- The **Power** LED is on.
- The **Cordless** and **Desk** LEDs are off.

The Cordless and Desk buttons currently have no function.

Troubleshooting

- If the **Power** LED is off, the base power supply is not properly connected.
- If the **Desk** LED is flashing, the base is not correctly connected to a digital station circuit in the main equipment.

DS1000 03.10.08 Release Notes

Cordless Telephone

Guidelines for Placing the Base

- For best results, the base unit should be placed in line-of-site with its handset.
- Cordless telephone range and reception can vary from site to site. Some of the things that may adversely affect range and reception are:
 - Placing the base against or close to a wall (particularly if the wall has metal studs).
 - Positioning the base close to a device that emits Electromagnetic Interference (EMI), such as a TV, radio, computer, fluorescent light, fax machine, or printer.
 - Installing the base close to other 900 Mhz devices, such as Symbol or Telex hand-held inventory devices.
 - Installing the base above a ceiling that uses foil-backed insulation.
 - Installing the base behind a door which can be closed, tinted windows, or one-way glass which will separate the base from the handset.
- Always raise the base unit antenna to its full vertical position.
- When installing more than one cordless in the same site:
 - Be sure the base units are at least 5 feet apart.
 - After installation, change each telephone's channel by pressing **CH** on the handset. This will minimize interference between your cordless telephones.

DS1000 03.10.08 Release Notes

Cordless Telephone

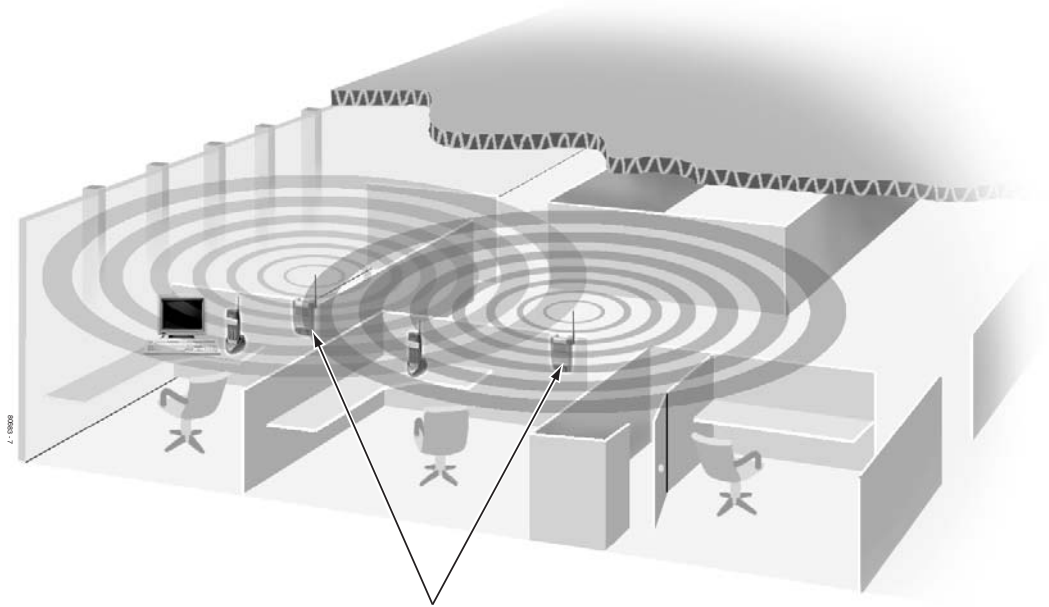

Correct line-of-site installation, away from devices that cause interference or locations that block signal.

Correct Installation Methods

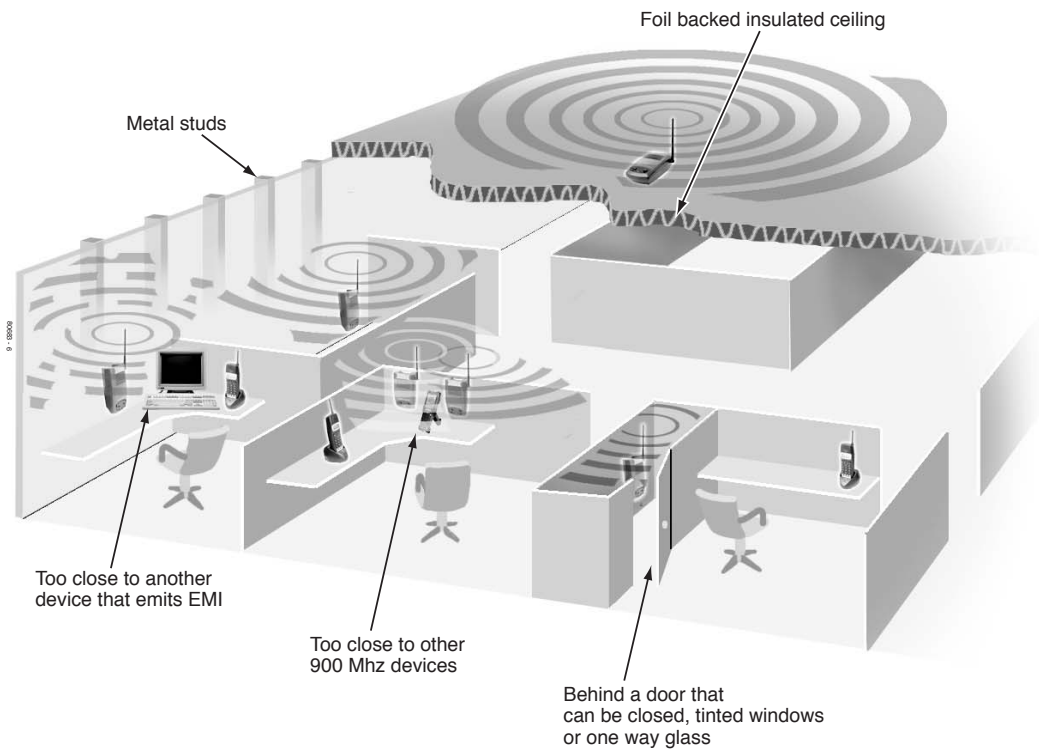

Incorrect Installation Methods

DS1000 03.10.08 Release Notes

Cordless Telephone

Wall-Mounting the Base

To mount the base on the wall:

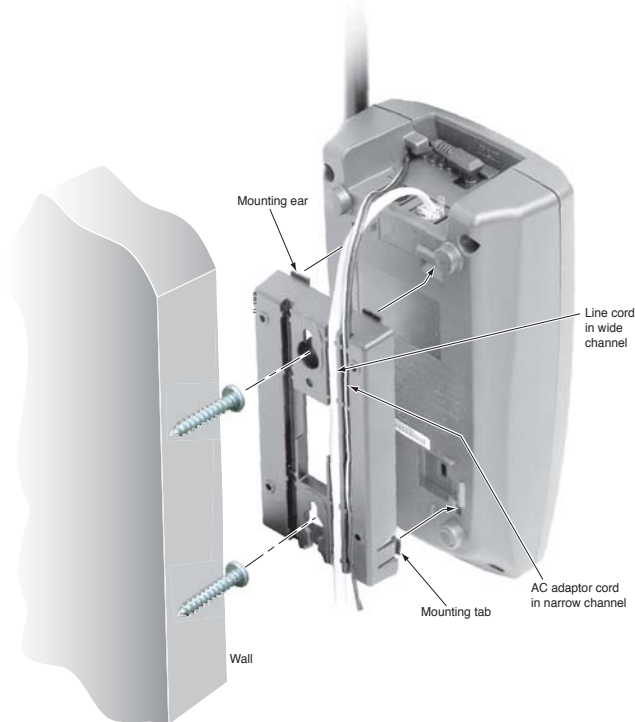

1. Run the base line cord in the wide wire channel as shown, but do not plug it into the base.
2. Run the AC adaptor cord in the narrow wire channel as shown, but do not plug it into the base.
3. Using suitable fasteners, attach the wall-mount bracket to the wall in the desired location.
*To make the base easier to remove later on, consider **not** tightening the fasteners all the way.*
4. Snap the base onto the wall-mount bracket.
Make sure the mounting ears fit all the way into their slots and the mounting tabs snap into place.
5. Connect the base line cord and AC adaptor cord to the base.

To remove the base from the wall:

If you did not tighten the fasteners, you can slide the base off the wall before going to the next step.

- Unplug the line cord and AC adaptor cord from the base.
- Press the mounting tabs to release the wall-mount bracket from the base.

DS1000 03.10.08 Release Notes

Cordless Telephone

To mount the base on a standard wall plate:

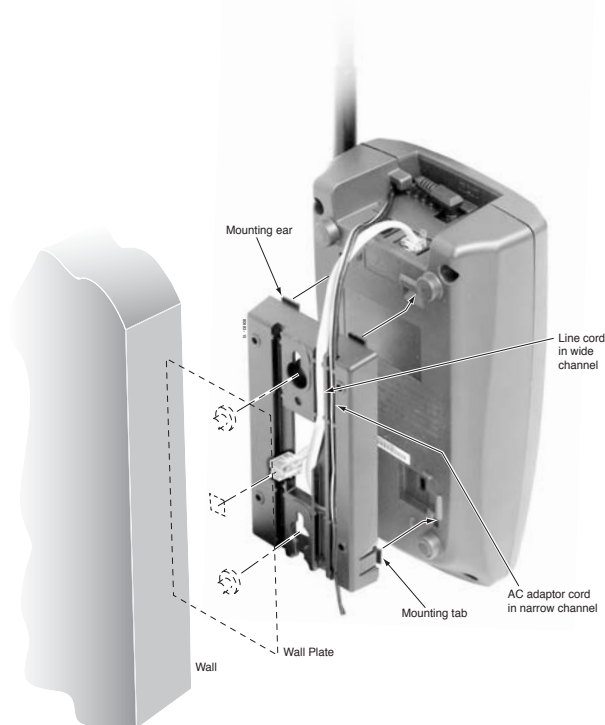

1. Snap the base onto the wall-mount bracket.
Make sure the mounting ears fit all the way into their slots and the mounting tabs snap into place.
2. Run a customer-provided short line cord in the wide wire channel as shown and plug it into the base.
3. Run the AC adaptor cord in the narrow wire channel as shown and plug it into the base.
4. Plug the other end of the short line cord into the wall plate modular jack.
5. Slide the wall-mount bracket onto the wall plate.

To remove the base from the wall:

1. Slide the wall-mount bracket off of the wall plate.
2. Unplug the short line cord from the wall plate.
3. Unplug the short line cord and AC adaptor cord from the base.
4. Press the mounting tabs to release the wall-mount bracket from the base.

DS1000 03.10.08 Release Notes

Cordless Telephone

Installing the Battery

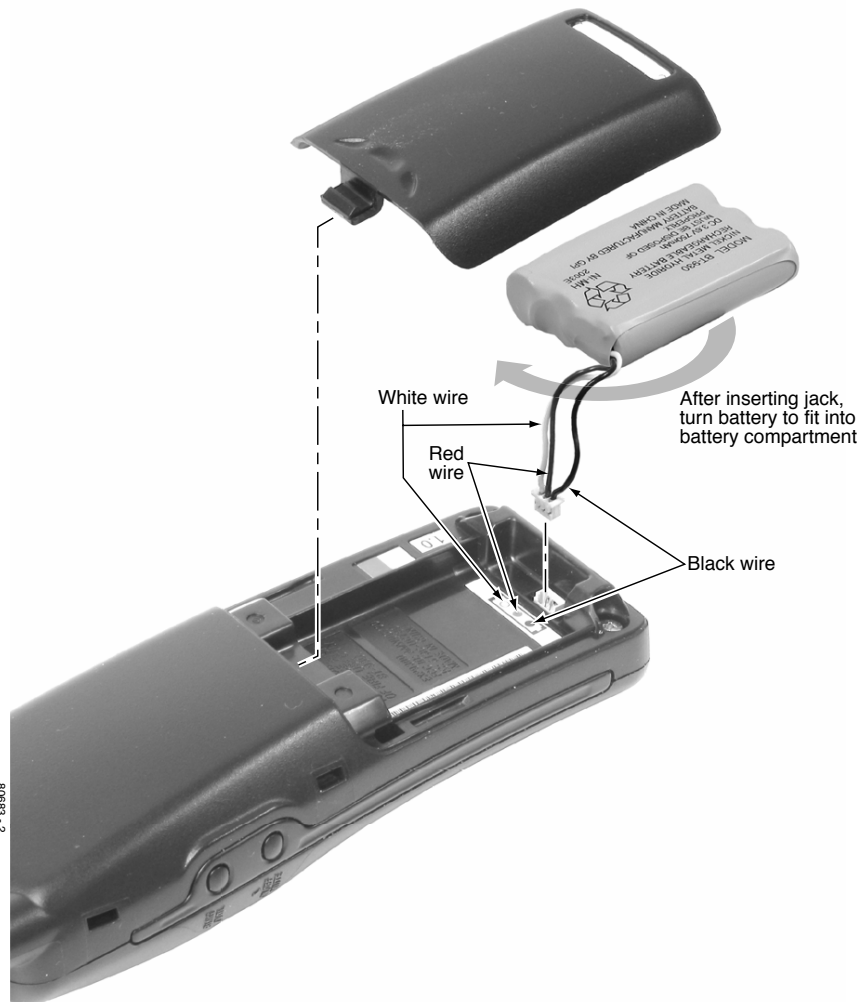

To install the battery in your handset:

1. Slide the battery cover off of the handset.
2. Insert the battery lead into the battery connector. Be sure to observe the polarity of the connection by lining up the black dot with the black wire.
3. Turn the battery around so it fits into the battery compartment.
4. Slide the battery cover back onto the handset until it snaps into place.

DS1000 03.10.08 Release Notes

Cordless Telephone

Installing the Charger and Charging the Handset

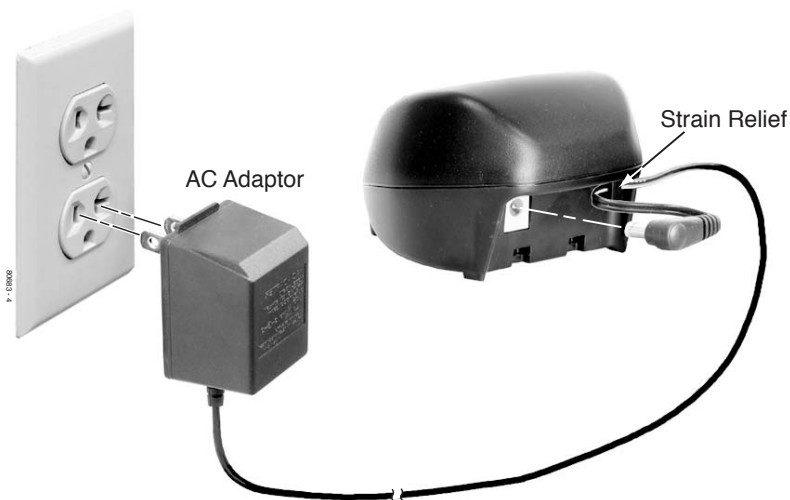

To connect the AC Adaptor to the charger:

1. Run the AC adaptor cord under the strain relief on the back of the charger as shown.
2. Plug the AC adaptor cord into the charger.
3. Plug the AC adaptor into AC outlet.
4. Insert the handset into the charger.

The handset must charge 5-8 hours in its charger prior to initial use.

*When the handset is correctly inserted into the charger, the **CHARGE LED** on the charger is on.*

Cleaning the Battery Charger Contacts



To clean the battery charger contacts:

- Use a pencil eraser or soft cloth to periodically (once a month) clean the battery contacts.

DS1000 03.10.08 Release Notes

Cordless Telephone

Wall-Mounting the Charger

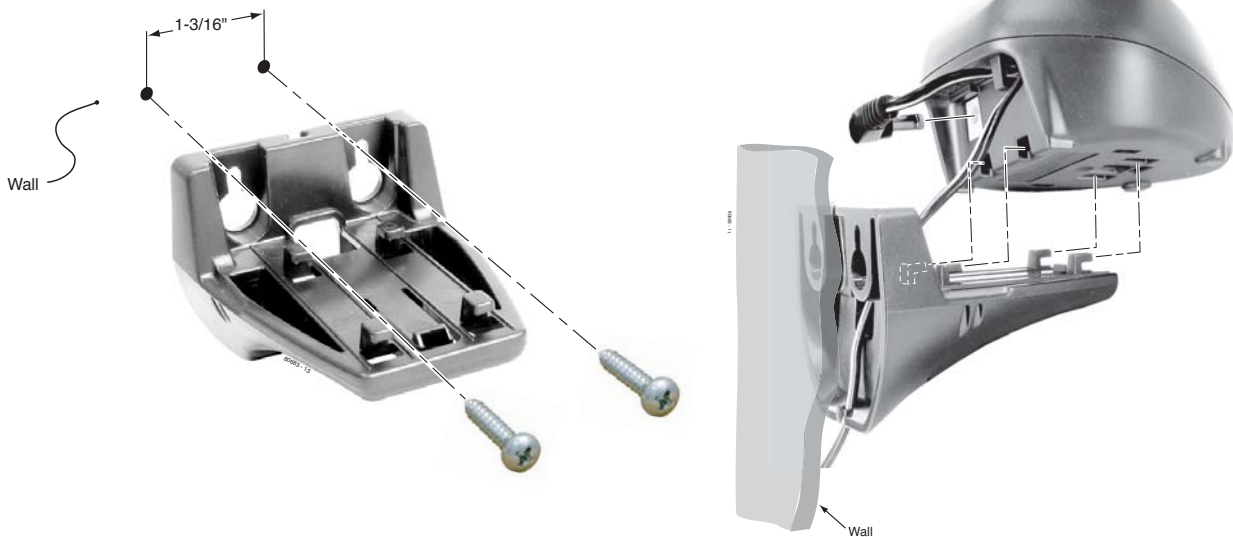

To wall-mount the charger:

1. Choose a suitable location for the charger wall-mount bracket within 6 feet of an AC outlet.
2. Install suitable fasteners 1 3/16" apart, leaving the heads out about 1/4".
3. Run the AC adaptor cord through the notch in the bottom of the wall-mount bracket and up through the rectangular cutout in the bracket.
4. Place the wall-mount bracket on the fasteners and tighten.
5. Run the AC adaptor cord through the strain relief on the back of the charger, then plug the cord into the charger.
6. Snap the charger onto the wall-mount bracket.
7. Plug the AC adaptor into the AC outlet.

DS1000 03.10.08 Release Notes

Cordless Telephone

Installing the Belt Clip

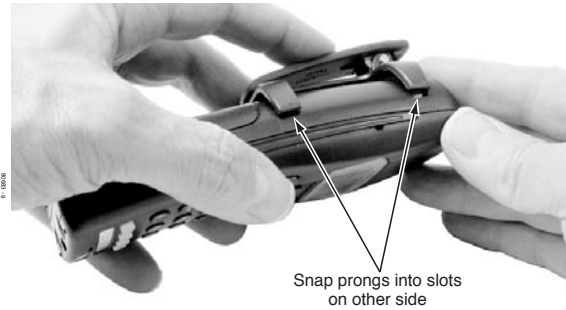
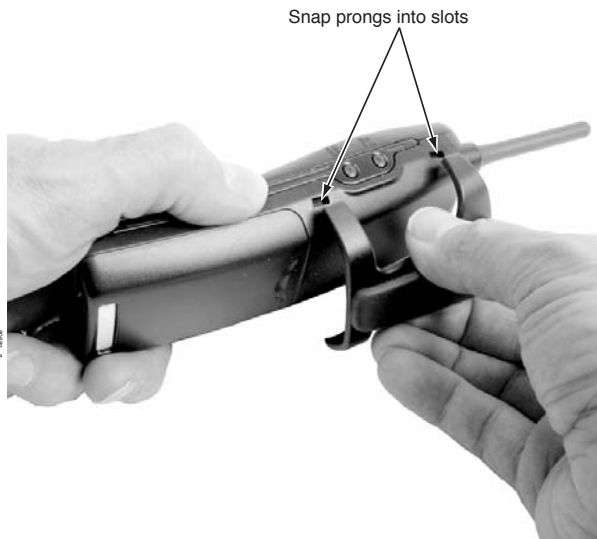

To install the belt clip:

- With the open end of the clip facing away from the antenna, snap the belt clip onto the handset.

To remove the belt clip:

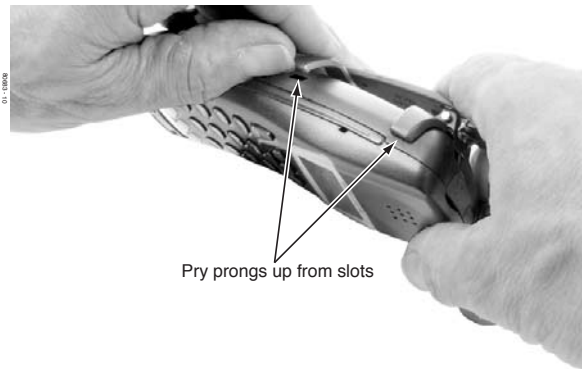

- Gently pry the belt clip prongs out of the slots in the handset.

DS1000 03.10.08 Release Notes

Cordless Telephone

Installing Headset P/N 750638 (M145)

To install the earloop (recommended):

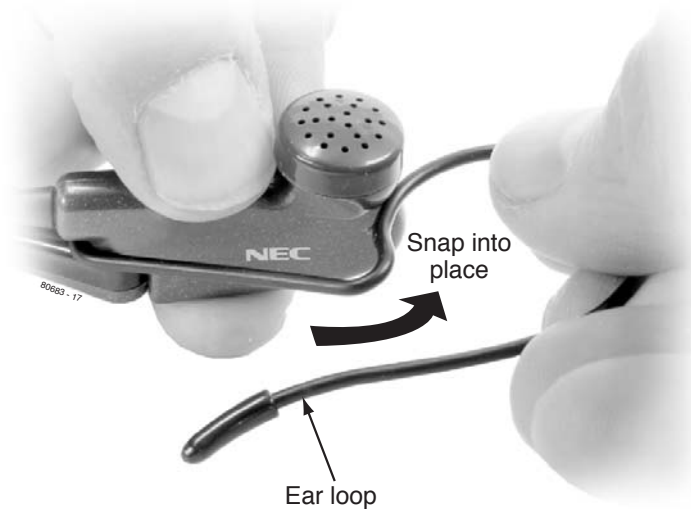

- Hook the earloop onto the headset and snap into place.
Installation for the right ear is shown. For the left ear, hook the earloop on the opposite side of the headset and reverse the microphone boom.

To install the ear cushion:



- Pull the ear cushion over the earpiece.

DS1000 03.10.08 Release Notes

Cordless Telephone

To connect the headset and use the controls:

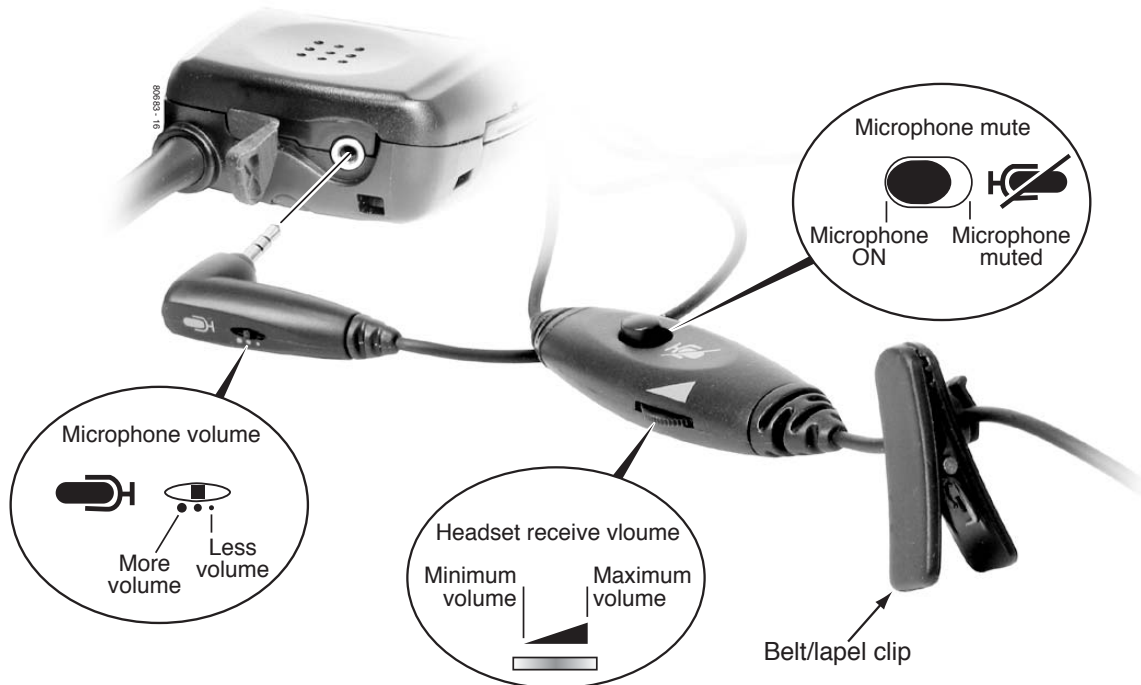

- Plug the headset into the **Headset Jack** on the top of the handset.
- Use the **Microphone Volume** control to adjust the volume of your headset's microphone (i.e., your voice).
- Use the **Headset Receiver Volume** control to adjust the volume of the receiver in your headset (i.e., your caller's voice).
- To temporarily turn off your headset microphone, slide the **Microphone Mute** switch into the *Microphone Muted* position.
- Clip the **Belt/Lapel Clip** to your belt or lapel to secure the headset cord.

DS1000 03.10.08 Release Notes

Cordless Telephone

Installing Headset P/N 750637 (M175)

To install the optional earloop:

- Snap the head band out of the ear piece.



- Remove the ear cushion.

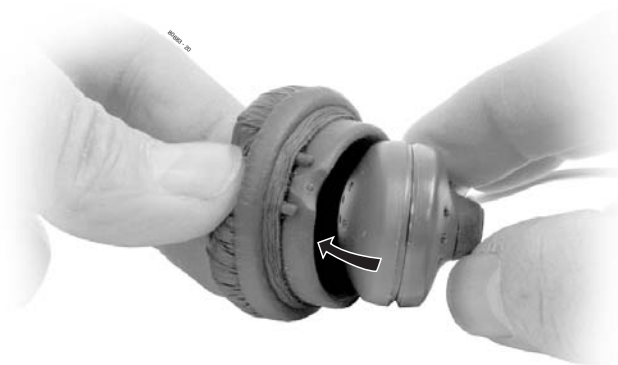

- Snap on the earloop ring. (Make sure the earloop ring lies flat against the microphone boom as shown.)

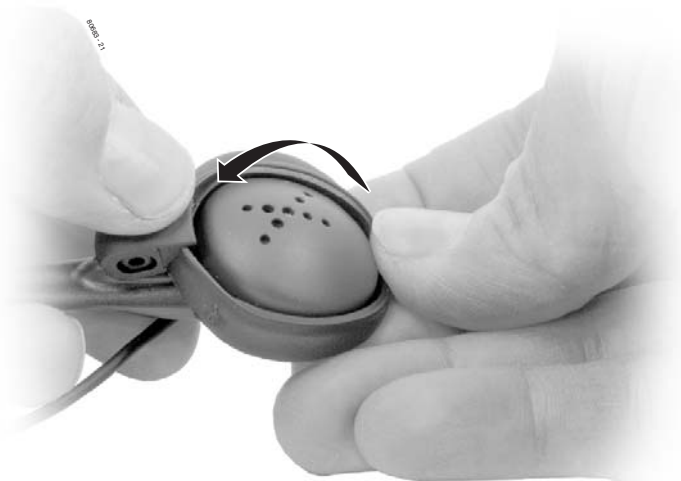

DS1000 03.10.08 Release Notes

Cordless Telephone

- Insert the earloop into the earloop ring. (Installation for the right ear is shown. For the left ear, insert the earloop from underneath the earloop ring.)



To connect the headset and use the controls:

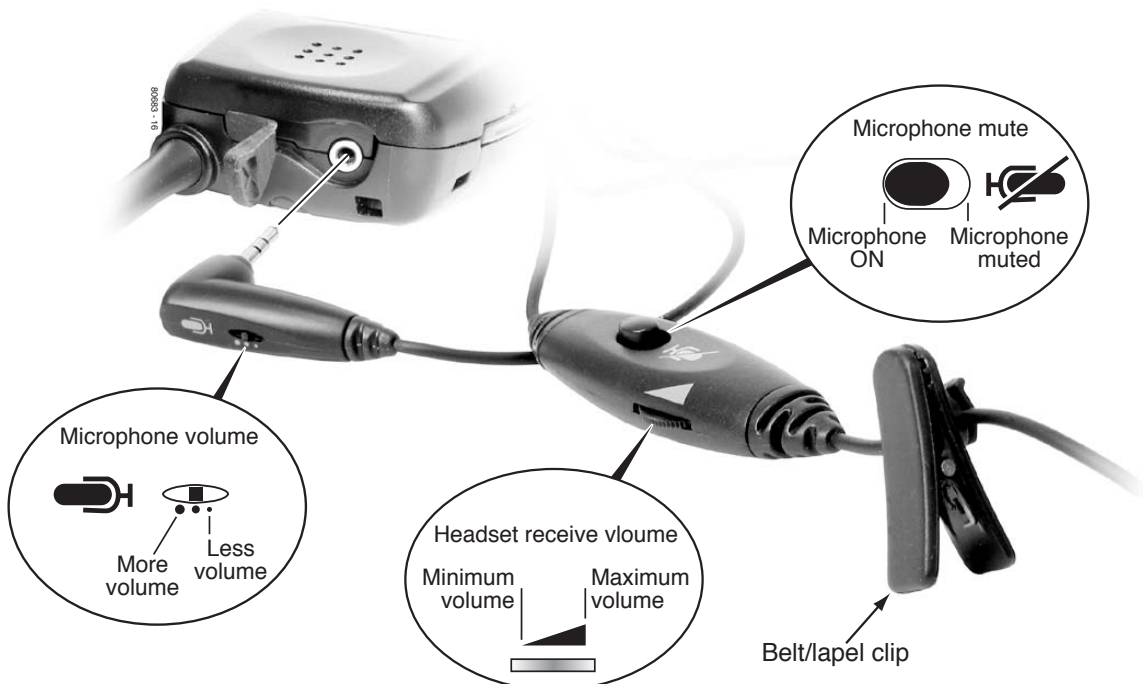

- Plug the headset into the **Headset Jack** on the top of the handset.
- Use the **Microphone Volume** control to adjust the volume of your headset's microphone (i.e., your voice).
- Use the **Headset Receiver Volume** control to adjust the volume of the receiver in your headset (i.e., your caller's voice).
- To temporarily turn off your headset microphone, slide the **Microphone Mute** switch into the *Microphone Muted* position.
- Clip the **Belt/Lapel Clip** to your belt or lapel to secure the headset cord.

DS1000 03.10.08 Release Notes

Cordless Telephone

Specifications

DS1000/2000 Cordless Telephone Specifications	
Transmission and Reception	
Transmission Method	900 MHz Digital Narrow Band FM
Receive/Transmit Frequency	902-905 MHz & 925-928 MHz
Frequency Control	Phase Lock Loop
PCM Type	32 Kbps ADPCM (Adaptive Differential Pulse Code Modulation)
Range	Up to 350 feet (depending on installation site) See <i>Guidelines for Placing the Base</i> on page 30 for some of the factors that affect range.
Bandwidth	± 50 KHz
Data Transmission Speed	688 BPS
Transmit Power4 mW approx.
Simultaneous Conversations (Channels)	30
Handset Battery	
Type	3.6V 750 mAh Nickel Metal Hydride Rechargeable Battery Pack
Charge Time	5-6 Hours max. to full charge
Life	Up to 7 hours talk time Up to 5 days standby
Power Requirements	
Power Supplies	
Charger (supplied)	9 VDC (yellow color-coded connector)
Base (supplied)	10 VDC (black color-coded connector)
Mechanical	
Handset	
Size	2" W x 1 1/4" D x 5 1/2" H (without antenna)
Weight	Approximately 5.1 oz. (with battery)
Base	
Size	4 1/4" W x 7 5/8" D x 2 1/4" H (without antenna)
Weight	Approximately 13.3 oz.
Charger	
Size	3 1/4" W x 3 1/2" D x 2 1/16" H
Weight	Approximately 2.3 oz.
Environmental	
Environmental Specifications	Maintain the same environmental conditions as you would for your DS1000/2000 keysets.
Miscellaneous	

DS1000 03.10.08 Release Notes

Cordless Telephone

DS1000/2000 Cordless Telephone Specifications	
Display Type	16 character, 2-line LCD with 4 Status Icons
Distinctive Ringing	3 ring tones (two volume levels each) and vibrate
The DS1000/2000 Cordless Telephone is hearing-aid compatible.	

Parts and Accessories

DS1000/2000 Cordless Telephone Parts and Accessories	
Part Number	Description
80683	DS1000/2000 Cordless Telephone
730632	EXP 9385 Charger Unit without AC Adaptor
730619	AD-970 AC Adaptor for Charger Unit
730618	EXP 9704 AC Adaptor for Base Unit
730634	EXP 9302 Belt Clip
750637	NEC Cordless Headset (M175)
750638	NEC Cordless Headset (M145)
730631	BT-930 Replacement Battery (Ni-Mh, DC 3.6V 750 mAh)
730633	EXP 9360 Wall Mount Bracket for Charger Unit
730608	EXP 9660 Wall Mount Bracket for Base Unit

DS1000 03.10.08 Release Notes

Cordless Telephone

Operation

Barge In

Barge In is disabled by default.

To Barge In on an extension or line:

1. Call busy extension or place call on busy line.
2. Dial **4**. (You hear 2 beeps.)
3. Join in the conversation in progress.

Call Coverage Keys

There are no Call Coverage keys assigned by default.

Call Coverage Key Flash Rates	
When the key is:	The covered extension is:
Off	Idle or not installed
On	Busy
Flashing Slowly	Ringing
Flashing Fast	In DND for intercom calls (option 2) or all calls (option 3)
Wink Off	In DND for outside calls (option 1)

To answer a call ringing or flashing a Call Coverage key:

- Press the flashing Call Coverage key.

To use your Call Coverage key to place a call to your idle co-worker:

- Press the Call Coverage key.

Call Forwarding

Call Forwarding is enabled by default.

To activate Call Forwarding:

1. Press **TALK** and dial ***3**.
2. Dial the Call Forwarding type:
 - 0** = Cancel your extension's Call Forwarding
 - 2** = Call Forwarding Busy/No Answer
 - 4** = Call Forwarding Immediate
 - 6** = Call Forwarding No Answer
3. Dial the destination extension, 0 for your operator, or the Voice Mail master number (e.g., 700).
4. Dial **2** to forward all calls; **8** to forward just outside calls.

The second line of the handset display shows that Call Forwarding is enabled (**FWD**) and the destination extension (number, name or **Voice Mail**).

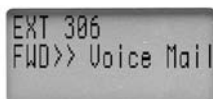

Call Forwarding Off Premise

Call Forwarding Off Premise is disabled by default.

1. Have your System Administrator set up your Personal Speed Dial bins.

DS1000 03.10.08 Release Notes

Cordless Telephone

2. Press **TALK** and dial ***33**.
3. Dial **2**.
4. Dial the Personal Speed Dial bin number (701-720) that Call Forwarding Off Premise should dial to forward your calls.
5. Press **HOLD**.
6. Dial **2** to forward all calls; **8** to forward just outside calls.

The second line of the handset display shows that Call Forwarding is enabled (**FWD**) and the destination number or name.

Call Waiting / Camp On

Call Waiting / Camp On is enabled by default.

To Camp-On to a busy extension:

1. Call a busy co-worker.
2. Dial **2**, but do not hang up.
If you hang up, the system converts your Camp-On to a Callback.
3. When your co-worker becomes free, you hear ringback.
4. Speak to your co-worker when they answer their waiting call.

Callback

Callback is enabled by default.

To leave a Callback at a busy co-worker:

1. Call your busy co-worker.
2. Dial **2** and hang up.
If you stay on the line, you will Camp-On to your busy co-worker.
3. When your busy co-worker becomes free, your phone will automatically ring.
4. Press **TALK** to answer.
5. Speak to your co-worker when the call goes through.

Caller ID

Caller ID is disabled by default.

If enabled in the system and provided by your telephone company, the handset display will show the Caller ID information as the call is ringing.

Second Call Caller ID and Third Party Caller ID Check are not available.

Central Office Calls, Answering

Central Office Calls, Answering is enabled by default.

To answer an outside call ringing your phone:

- Press **TALK**.
Your handset will not vibrate while it is in its charger base.

Central Office Calls, Placing

Central Office Calls, Placing is enabled by default.

To place an outside call using a line or loop key:

- Press the line or loop key.

DS1000 03.10.08 Release Notes

Cordless Telephone

To place an outside call over a specific line using Line Dial-Up:

1. Press **TALK**.
2. Dial **#9**.
3. Dial the line number (e.g., 01 for line 1).

To place an outside call using Direct Line Access):

1. Press **TALK**.
2. Dial **1**.
3. Dial the line number (e.g., 01 for line 1).

To place an outside call using Line Group Access:

- Press **TALK** and dial a Line Group Access Code (90-98).
If you hear dial tone as soon as you dial 9, your system has Line Group Routing. A line group has been automatically selected for you.

Conference

Conference is enabled by default.

To set up a Conference:

1. Establish Intercom or outside call.
2. Press **CONF**.
3. Dial extension you want to add,
OR
Place or answer an outside call,
OR
Retrieve call from Park Orbit.
4. Press **CONF** to set up the Conference.
*You see: **CONFERENCE CALL***

Directed Call Pickup

Directed Call Pickup is enabled by default.

To use Directed Call Pickup to intercept a call to a co-worker's extension:

1. Press **TALK**.
2. Dial ******.
3. Dial your co-worker's extension number.
To pick up a call ringing an attendant, dial the attendant's extension number (e.g., 300). Do not dial 0 or 01-04.

Distinctive Ringing

Distinctive Ringing is enabled by default.

To change your handset's ringing tone:

- *Outside calls ring with two short rings followed by one long.
Intercom calls ring with one long ring.*
While idle, press **RING/VOL**.
*You hear the selected ringing tone. The tone will ring for about 2 seconds unless you press **RING/VOL** to select another tone.*

DS1000 03.10.08 Release Notes

Cordless Telephone

There are four ring tones from which to choose. The default setting is hi-lited.

Display Name	Description
Ring Type A High	High pitch ring, loud
Ring Type A Low	High pitch ring, soft
Ring Type B High	Low pitch ring, loud
Ring Type B Low	Low pitch ring, soft
Ring Type C High	High pitch warble, loud
Ring Type C Low	High pitch warble, soft
Ring Off	Vibrate ¹

¹ While the handset is in the charger, the *Ring Off* setting uses *Ring Type A Low*.

To turn the ringer off:

- While your phone is idle, press and hold **ON/OFF MUTE** for five seconds.
The OFF icon will display indicating that the ringer is off.

Do Not Disturb Override

Do Not Disturb Override is disabled by default.

To use Do Not Disturb Override:

1. Dial your co-worker.
2. When you hear DND tone, dial **1**.
3. The system automatically places a ringing Intercom call to your co-worker.

Extension Hunting

Extension Hunting is disabled by default.

To temporarily install or remove your extension from your UCD group:

1. Press **TALK**.
2. Dial ***5**, then . . .
3. Dial **4** to return your extension to your group, or
Dial **6** to remove your extension from your group.

Forced Trunk Disconnect

Forced Trunk Disconnect is disabled by default.

To disconnect a busy outside line:

1. Press line key for busy outside line.
OR
Press **TALK** and dial the line's Line Access Code (e.g., 101 for line 1).
2. Dial **#** to disconnect the line.
3. Press line key and dial the number you want to call.

DS1000 03.10.08 Release Notes

Cordless Telephone

Group Call Pickup

Group Call Pickup is disabled by default.

To answer a call ringing a phone in your Pickup Group:

- Press **TALK** and dial ***#**.
OR
Press the flashing Group Pickup key.

Group Ring

Group Ring is disabled by default.

To answer a call ringing into your Ring Group:

- Press **TALK**.

Hold

Hold is enabled by default.

To place an outside call on System Hold:

- Press **HOLD**.
*The line key flashes fast to indicate that it is on Hold.
The line will recall with a distinctive “wink-on” flash rate if you leave it on Hold too long.*

To place an outside call on Exclusive Hold:

- Press **HOLD** twice.
The line key flashes with a distinctive “wink-on” flash rate to show when it is on Hold or recalling.

To place an Intercom call on Hold:

- Press **HOLD**.

To pick up an outside call on Hold:

- Press the flashing line key.

To pick up an Intercom call on Hold:

- Press **TALK + HOLD**.

Hotline

Hotline is disabled by default.

Hotline Key Flash Rates	
When the key is:	The covered extension is:
Off	Idle or not installed
On	Busy
Flashing Fast	In DND for intercom calls (option 2) or all calls (option 3)
Wink Off	In DND for outside calls (option 1)

To place a call to your Hotline partner:

- Press your Hotline key.

To Transfer your outside call to your Hotline partner:

1. While on the call, press your Hotline key.

DS1000 03.10.08 Release Notes

Cordless Telephone

2. (Optional) Announce the call.
3. Press **TALK** to hang up and Transfer the call.

To answer a call from your Hotline partner.

- Press **TALK**

Intercom

Intercom is enabled by default.

To place an Intercom call:

- Press **TALK** + Dial your co-worker's extension number.
To call a Door Box, dial the Door Box extension number. You cannot control the Door Box relay.

To answer an Intercom call ringing your phone:

- Press **TALK**.

Last Number Redial

Last Number Redial is enabled by default.

To redial your last call:

- Press a line key + **REDIAL**.

Meet Me Conference

Meet Me Conference is enabled by default.

To set up a Meet-Me Conference:

1. Press **TALK**.
2. Dial ***1** + Dial a page zone number + Announce Meet-Me Conference code (#11 or #12).
3. Press **TRANSFER** + Dial the announced Meet-Me Conference code.

To join a Meet-Me Conference:

1. Listen for page announcing the Meet-Me Conference.
2. Press **TALK**.
3. Dial the announced Meet-Me Conference code (#11 or #12).

Message Waiting

Message Waiting is available by default, but only in systems without Voice Mail installed.

To leave a Message Waiting:

- Place Intercom call to co-worker + Dial **8**.
The extension you call can be unanswered, busy, or in Do Not Disturb.

To answer a Message Waiting:

Your "New Mail" icon indicates that you have a Message Waiting.

- Press **TALK** + Dial ***8**.

DS1000 03.10.08 Release Notes

Cordless Telephone

Microphone Mute

Microphone Mute is enabled by default.

To mute your handset's microphone:

- While on a call, press **ON/OFF MUTE**.
The TALK icon flashes while your microphone is muted.

To cancel Microphone Mute:

- While on a call, press **ON/OFF MUTE**.
The TALK icon stops flashing.
Microphone Mute automatically cancels when you hang up.

Monitor / Silent Monitor

Monitor / Silent Monitor is disabled by default.

To Monitor a call:

- Call busy co-worker + Dial **6**.

Night Service / Night Ring

Night Service is disabled by default.

To activate or deactivate Night Service:

- Press your Night key.

To answer a call ringing the paging system at night:

- Press **TALK** + Dial ***0**.

Off-Hook Signaling

Off-Hook Signaling (Camp-On tones) is available for Intercom calls by default.

While busy on a call, you can receive Camp-On tones when another call is trying to get through.

Paging

Paging is available by default.

To make an Internal Paging Announcement:

1. Press **TALK**.
2. Dial ***1**.
3. Dial the Page Zone number (1-7 or 0 for All Call).
4. Make announcement and hang up.

Park

Park is available by default.

To Park a call in a System Park Orbit:

1. While on an outside call, press **TRANSFER**.
2. Dial ***** and the System Park Orbit (60-69).
3. Press **TALK** to hang up.

To retrieve a call from a System Park Orbit:

- Press **TALK** + Dial ***** and the System Park Orbit (60-69).

DS1000 03.10.08 Release Notes

Cordless Telephone

To Park a call at a co-worker's extension (using Personal Park):

1. While on an outside call, press **TRANSFER**.
2. Dial ******.
3. Dial the number of the extension at which you want to Park the call.
4. Press **TALK** to hang up.

To retrieve a call parked at a co-worker's extension:

- Press **TALK** + Dial ****** and the number of the extension at which the call is parked.

Prime Line Preference

Intercom Prime Line Preference is enabled by default.

To place a call on your Prime Line:

- Press **TALK** + Dial the call normally.
To bypass your Prime Line, press another line key before pressing TALK.

Privacy Release Groups

Privacy Release Groups is disabled by default.

To join an outside call with a member of your Privacy Release Group:

- Press the busy line key.
*Your display shows: **CONFERENCE CALL***

To prevent a member of your Privacy Release Group from joining your call:

1. Place or answer an outside call on a line key.
2. Press the line key.
3. Press the line key again to allow a co-worker to join in.

Programmable Function Keys

By default, keys 1-4 are line keys for outside lines 1-4. *You can only set up cordless telephone function keys from system programming.*

Cordless Telephone Programmable Function Keys			
Description	Code	BLF	Operation
Undefined	00	-	-
Loop Key, Switched	01	<u>Off:</u> Idle <u>On:</u> You are on a loop key call. <u>Slow Flash:</u> Call is ringing the loop key	<u>Incoming:</u> Press key to answer outside call. <u>Outgoing:</u> Press key + Dial trunk group (0-9) to place call.
Loop Key, Fixed	02 + Trunk Group (90-98)	<u>Off:</u> Idle <u>On:</u> You are on a loop key call. <u>Slow Flash:</u> Call is ringing the loop key	Press key to place or answer outside call.
Line Key	03 + Trunk number (e.g., 1)	<u>Off:</u> Idle <u>On:</u> Line busy <u>Slow Flash:</u> Line ringing	Press key to place or answer outside call.

DS1000 03.10.08 Release Notes

Cordless Telephone

Cordless Telephone Programmable Function Keys			
Description	Code	BLF	Operation
Park Orbit Key	04 + System Orbit (60-69)	Off: Park Orbit idle. On: Call parked in orbit by a co-worker Fast Flash: Has a call you parked.	Press key to Park or retrieve call.
Hotline Key	05 + Partner's extension	Off: Partner is idle On: Partner is ringing or busy Fast Flash: Partner in DND for Intercom calls (option 2) or all calls (option 3). Wink Off: Partner in DND for outside calls (option 1)	Press key to call or Transfer to Hotline partner.
Call Coverage Immediate Ring	06 + Covered extension	Off: Covered extension idle. On: Covered extension busy. Slow Flash: Co-worker ringing Fast Flash: Covered extension in DND for Intercom calls (option 2) or all calls (option 3). Wink Off: Covered extension in DND for outside calls (option 1)	Press key to call or pick up a call ringing the covered extension.
Call Coverage No Ring	07 + Covered extension		
Call Coverage Delay Ring	08 + Covered extension		
Group Pickup Immediate Ring	09 + Pickup Group (1-8)	Off: Call not ringing pickup group Slow Flash: Call ringing pickup group	Press key to answer call ringing pickup group.
Group Pickup No Ring	10 + Pickup Group (1-8)		
Group Pickup Delay Ring	11 + Pickup Group (1-8)		
Page Zone Key	13 + Page Zone (1-7, 0 for all call)	Off: Page Zone idle. On: Page Zone busy.	Press to Page into the assigned zone.
System Speed Dial Key	14 + System bin number (200-299)	No BLF.	Press to dial stored number.
Personal Speed Dial Key	15 + Personal bin number (701-720)		
Call Timer Key	Not available.		
Voice Mail Record Key	17	Off: Recording off. On: Recording being set up. Fast Flash: Recording on.	Press to start and stop recording conversation into mailbox.
Night Key	18 + CLEAR	Off: System in Day Mode. On: System in Night Mode.	Press to switch the day/night mode of the system.
Split Key	20	No BLF.	Press to switch between calls. See the <i>Split</i> feature for more.
ICM Directory Key	Not available.		

DS1000 03.10.08 Release Notes

Cordless Telephone

Cordless Telephone Programmable Function Keys			
Description	Code	BLF	Operation
Reverse Voice Over Key	23 + Covered extension	<u>Off:</u> Covered extension idle. <u>On:</u> Covered extension busy. <u>Slow Flash:</u> Co-worker ringing <u>Fast Flash:</u> Covered extension in DND for Intercom calls (option 2) or all calls (option 3). <u>Wink Off:</u> Covered extension in DND for outside calls (option 1)	<ul style="list-style-type: none"> • While on a handset call, press key to place private Intercom call to co-worker. • While idle, press to call co-worker.
Message Center / Voice Mail Key	24 + Your extension or Message Center Extension	<u>Off:</u> No messages in associated mailbox <u>Fast Flash:</u> Messages are waiting in associated mailbox	<ul style="list-style-type: none"> • TALK + Press to call associated mailbox.
Save Key	25	No BLF	<ul style="list-style-type: none"> • While on a call, press key to Save number you just dialed. • While idle, press key to redial previously saved number.
Account Code Key	26	<u>Off:</u> Account Code inactive. <u>On:</u> Account Code active for call. <u>Fast Flash:</u> Account Code entry mode.	Press to enter Account Code, then press again to return to call.
Call Forwarding Key	27	<u>Off:</u> Call Forwarding disabled. <u>Fast Flash:</u> Extension in Call Forwarding programming mode. <u>Wink Off:</u> Call Forwarding enabled.	<ul style="list-style-type: none"> • While idle, enters Call Forwarding programming mode (the same as pressing TALK and dialing *3). • While busy, switches Call Forwarding on and off.
Headset Key	Not available.		

Removing Lines and Extensions

Removing Lines and Extensions is disabled by default.

To removes lines and extensions from service:

1. Press **TALK**.
2. Dial **#40**.
3. Dial the number of the extension you want to remove or return to service (e.g., 300).
OR
Dial the number of the trunk you want to remove or return to service (e.g., 101).
4. Dial **4** to return or **6** to remove.

Reverse Voice Over

Reverse Voice Over is disabled by default.

Reverse Voice Over Key Flash Rates	
When the key is:	The covered extension is:
Off	Idle or not installed
On	Busy

DS1000 03.10.08 Release Notes

Cordless Telephone

Reverse Voice Over Key Flash Rates	
When the key is:	The covered extension is:
Flashing Fast	In DND for intercom calls (option 2) or all calls (option 3)
Wink Off	In DND for outside calls (option 1)

To place a Reverse Voice Over call:

- While on a handset call, press and hold your Reverse Voice Over key.
You hear two beeps, then conversation with your co-worker in your handset.

To return to your initial caller:

- Release your Reverse Voice Over key.

To place a call to the co-worker assigned to your Reverse Voice Over key:

- While your handset is idle, press your Reverse Voice Over key.
You hear two beeps, then conversation with your co-worker.

Ringling Line Preference

Ringling Line Preference is enabled by default.

- With Ringling Line Preference enabled, pressing **TALK** will answer the ringing call.
*To bypass Ringling Line Preference, press a line key or Programmable Function Key before pressing **TALK**.*
- With Ringling Line Preference disabled, pressing **TALK** will provide Intercom dial tone (instead of answering the ringing call).

Save Number Dialed

Save Number Dialed is disabled by default.

To save the outside number you just dialed:

- Press your Save Programmable Function Key.

To redial the saved number:

- Press your Save Programmable Function Key.
If the line you select is busy, you may be able to dial 2 to wait for the line to become free.

Speed Dial

There are no Speed Dial numbers stored by default.

Note: *You cannot program Personal or System Speed Dial bins from your Cordless Telephone. See your Communications Manager.*

To dial a System Speed Dial number:

- Press **TALK** + Dial # + Dial the bin number (e.g., 200).

To dial a Personal Speed Dial number:

- Press **TALK** + Dial # + Dial the bin number (e.g., 200).

Split

Slit is disabled by default.

You must have a Split key programmed to use this feature. Refer to the Programmable Function Keys feature for more.

DS1000 03.10.08 Release Notes

Cordless Telephone

To Split between your current Intercom call and a new Intercom call:

1. Press **HOLD** to place your current Intercom call on Hold.
2. Wait for your display to return to idle.
3. Place or answer second Intercom call.
4. Press the Split key to switch between your two Intercom calls.

To Split between your current outside call and an Intercom call:

1. Press **TRANSFER** to place the outside call on Hold.
2. Place or answer waiting Intercom call.
3. Press the Split key to switch between the Intercom call and the outside call.

To Split between your current Intercom call and an outside call:

1. Press **HOLD** to put your Intercom call on Hold.
2. Press a line key to place or answer your outside call.
3. Press your Split Programmable Function Key to switch between the calls.

To Split between your current outside call and a waiting Intercom call:

1. Press **TRANSFER** to place your current outside call on Hold.
2. Press **TALK** to hang up.
3. Place or answer new outside call.
4. Press the Split key to switch between your two calls.

Tandem Trunking

Tandem Trunking is disabled by default.

To set up a tandem call (Unsupervised Conference):

1. Place or answer an outside call.
2. Press **CONF**.
3. Place or answer another outside call.
4. Press **CONF + TALK** to hang up.

*You can optionally press **HOLD** to place the Conference on Hold. Press one of the line keys + **CONF** to reinstate the tandem call.*

To disconnect a tandem call (using Forced Trunk Disconnect):

- Press line key for busy line (or use Direct Line Access) + **#** to disconnect the line.

To Barge In on a tandem call:

Use this procedure to rejoin a Conference already in progress.

- Press line key for busy line (or use Direct Line Access) + **4** to Barge In.

Transfer

Transfer is enabled by default.

To Transfer your call:

1. Do not hang up.
2. Press **TRANSFER**.
3. Dial your co-worker's extension number.

DS1000 03.10.08 Release Notes

Cordless Telephone

You can also Transfer the call to a Ring Group or UCD Group master number.

4. Announce the call + Press **TALK** to make a Screened Transfer.
OR
Press the flashing line key to return to the call if your co-worker doesn't want it.
OR
Press **TALK** to send the call through unscreened.

To Transfer your call to a co-worker's mailbox:

1. Do not hang up.
2. Press **TRANSFER** + Dial your co-worker's extension.
3. Dial **8**.
*To Transfer the call to your own mailbox, press **your own** Message Center key.*
4. Press **TALK** to hang up.

Trunk (Line) Queuing and Callback

Trunk (Line) Queuing and Callback are disabled by default.

To queue for a busy line:

1. Press line key for busy line.
OR
Press **TALK** and dial line's Direct Line Access code (e.g., 101 for line 1).
2. Dial **2**; do not hang up.
3. When the line becomes free, you automatically connect.
When you hear dial tone from the line, you can place your call again.

To leave a Line Callback for a busy line:

1. Press line key for busy line.
OR
Press **TALK** and dial line's Direct Line Access code (e.g., 101 for line 1).
2. Dial **2** + Hang up.
3. When the line becomes free, the system automatically calls you back.
You must answer within 4 rings or the system cancels the Callback.

Voice Mail

Voice Mail is disabled by default.

The "new mail" icon indicates when you have messages. If you have a Message Center key for your own extension, it will flash when you have new messages.

To call your mailbox:

- Press **TALK** + Dial ***8**.
OR
Press **TALK** + Press **your own** Message Center key.
If requested by Voice Mail, enter your security code.

To leave a message in the mailbox of an unanswered extension:

- Dial **8**.
The Voice Mail system will prompt you to leave a message.

To activate or cancel Call Forwarding to your mailbox:

1. Press **TALK** and dial ***3**.

DS1000 03.10.08 Release Notes

Cordless Telephone

2. Dial the Call Forwarding type:
 - 0** = Cancel your extension's Call Forwarding
 - 2** = Call Forwarding Busy/No Answer
 - 4** = Call Forwarding Immediate
 - 6** = Call Forwarding No Answer
3. Dial the Voice Mail master number (e.g., 700).
4. Dial **2** to forward all calls; **8** to forward just outside calls.

To Transfer your call to a co-worker's mailbox:

1. Do not hang up.
2. Press **TRANSFER** + Dial your co-worker's extension.
3. Dial **8**.
*To Transfer the call to your own mailbox, press **your own** Message Center key.*
4. Press **TALK** to hang up.

To record your active call in your Mailbox:

Only one party on a call can use Conversation Record at any one time. This includes Intercom calls and Conference calls.

- While on a call, press your Voice Mail Record key.
Your Voice Mail Record key lights while your system calls your mailbox. Once recording begins, the key flashes fast and you hear the voice prompt, "Recording."

To stop Conversation Record:

- Press your Voice Mail Record key.

To call the Message Center:

The Message Center key flashes fast when there are new messages in the Message Center Mailbox.

You can have a Message Center key for your own extension, if desired.

- Press **TALK** + Press the Message Center key.

To Transfer a call to the Message Center:

Press the Message Center key + Press **TALK** to hang up.

Your caller will be prompted to leave a message in the Message Center mailbox.

Voice Over

Voice Over is disabled by default.

To initiate a Voice Over to a busy extension:

- Dial 9.
You hear two beeps, then you can speak with your co-worker.

A co-worker cannot send a Voice Over to your extension.

Volume Control

Volume Control is enabled by default.

The adjust volume while on a call:

- Press **RING/VOL**.
This adjusts the handset receiver volume, not the volume of your transmitted voice. There are four volume levels: Low, Medium, High, and Maximum.

DS1000 03.10.08 Release Notes

Cordless Telephone

When you hang up, your handset retains the volume level you selected.

Walking Class of Service

Walking Class of Service is disabled by default.

To enable Walking Class of Service at a co-worker's cordless telephone:

1. Press **TALK** + Dial **##0**.
2. Dial your own extension number + **HOLD**.
3. Enter your PIN number + **HOLD**.
4. Place any call or use any feature allowed by your Toll Restriction and Class of Service settings.

You can place additional calls. Walking Class of Service will automatically deactivate after 10 seconds.

Cordless Telephone Feature Summary

DS1000/2000 Cordless Telephone Feature Summary (Sheet 1 of 3)			
Feature	Available	Default	Comment
Alphanumeric Display	Yes	Enabled	Handset feature
Auto Redial	No	N/A	
Background Music	No	N/A	
Barge In	Yes	Disabled	
Call Coverage Keys	Yes	Disabled	
Call Forwarding	Yes	Enabled	
Call Forwarding Off Premise	Yes	Disabled	
Call Timer	No	N/A	
Call Waiting/Camp On	Yes	Enabled	
Callback	Yes	Enabled	
Caller ID	Yes	Disabled	Second Call and Third Party Caller ID not available
Caller ID Logging	No	N/A	
Central Office Calls, Answering	Yes	Enabled	
Central Office Calls, Placing	Yes	Enabled	Some codes are disabled by default.
Conference	Yes	Enabled	
Dial Number Preview	No	N/A	
Direct Station Selection	No	N/A	
Direct Station Selection, Console	No	N/A	
Direct Trunk Access	Yes	Operator Only	
Directed Call Pickup	Yes	Enabled	
Directory Dialing	No	N/A	
Distinctive Ringing	Yes	Enabled	Handset feature
Do Not Disturb	No	N/A	
Do Not Disturb Override	Yes	Disabled	
Extension Locking	No	N/A	

DS1000 03.10.08 Release Notes

Cordless Telephone

DS1000/2000 Cordless Telephone Feature Summary (Sheet 2 of 3)			
Feature	Available	Default	Comment
Extension Hunting	Yes	Disabled	
Flash	No	N/A	
Forced Trunk Disconnect	Yes	Operator Only	
Group Call Pickup	Yes	Disabled	
Group Listen	No	N/A	
Group Ring	Yes	Disabled	
Handsfree	No	N/A	
Headset Compatibility	Yes	Enabled	Handset feature
Hold, Exclusive	Yes	Enabled	
Hold, Intercom	Yes	Enabled	
Hold, System	Yes	Enabled	
Hotline	Yes	Disabled	
Interactive Soft Keys	No	N/A	
Last Number Redial	Yes	Enabled	Handset feature. Enhanced Last Number Redial not available.
Meet Me Conference	Yes	Enabled	
Message Waiting	Yes	Enabled	Scrolling through waiting messages not available.
Microphone Mute	Yes	Enabled	
Monitor/ Silent Monitor	Yes	Disabled	
Night Service/Night Ring	Yes	Disabled	
Off-Hook Signaling	Yes	Enabled for ICM	Camp-On only. Off-hook ringing not available.
Paging	Yes	Enabled	
Park	Yes	Enabled	
Prime Line Preference	Yes	Intercom Prime Line	
Privacy Release Groups	Yes	Disabled	
Programmable Function Keys	Yes	Line Keys 1-4	
Removing Lines and Extensions from Service	Yes	Operator only	
Reverse Voice Over	Yes	Disabled	
Ringing Line Preference	Yes	Enabled	
Save Number Dialed	Yes	Disabled	
Selectable Display Messaging	No	N/A	
Speed Dial, Extension	Yes	Enabled - No numbers stored	Numbers must be stored via system programming

DS1000 03.10.08 Release Notes

Cordless Telephone

DS1000/2000 Cordless Telephone Feature Summary (Sheet 3 of 3)			
Feature	Available	Default	Comment
Speed Dial, System	Yes	Enabled --No numbers stored	Numbers must be stored via system programming or another non-cordless user
Split	Yes	Disabled	
Tandem Trunking	Yes	Disabled	
Time and Date	No	N/A	
Transfer	Yes	Enabled	
Trunk (Line) Queuing	Yes	Operator only	
User Programmable Features	No	N/A	
Voice Mail	Yes	Disabled	Handset has an icon for new messages. Answering Machine Emulation and Message Check are not available.
Voice Over	Yes	Disabled	Handset cannot receive a Voice Over.
Volume and Contrast Control	Yes	Enabled	Volume control is a handset feature. Contrast Control is not available.
Walking Class of Service	Yes	Disabled	
Programming the System	No	N/A	Handset cannot enter programming mode

DS100003.10.12 Release Notes

New Features in 03.10.12

There are no New Features in this release.

DS1000 03.10.12 Release Notes

Enhanced Features in 03.10.12

Message Center

Simplified Message Center Access

A keyset user with a Message Center key can call the Message Center just by pressing the key. In prior software versions, it was necessary to lift the handset or press **SPK** first.

To call the Message Center:

- Press the Message Center key.

In prior software levels, pressing the Message Center key while idle would display the number of new messages waiting in the Message Center. This capability is no longer available.

DS1000 03.10.12 Release Notes

Software Corrections in 03.10.12

Caller ID

New DSP Code To Fix Caller ID Related System Reset Problem

Software version 03.10.12 provides a correction to the system's DSP code that corrects a bug in the Caller ID Transmitter. The bug, introduced in software version 03.10.08, could potentially cause system resets and loss of other DSP resources (such as DTMF detection). Note that system processes involving the Caller ID Transmitter include:

- Sending Caller ID data to a single line extension (if the extension is programmed to receive Caller ID).
- Sending FSK Message Waiting signals to a single line extension (if the extension is programmed to receive FSK Message Waiting).

Caller ID Logging

Logs For December Do Not Display Correctly

Software version 03.10.12 corrects a problem that first occurred in version 03.10.08 in which Caller ID logs for calls in December would display "UNLISTED" instead of the correct month. (The "YESTERDAY" and "TODAY" records during December would display correctly, however.)

Central Office Calls, Answering

Out-Of-Range Data While Programming Ring Assignments

An out-of-range data programming error while programming extension ring assignments is corrected in software version 03.10.12. The following problem occurred in version 03.10.08:

1. Enter program **1805-Ring Assignments**.
2. Press **HOLD**, then enter 500.
3. Press **Vol Up** to scroll past the telephone extension numbers.

A similar problem also occurred while programming **1806-Ring Type Configuration** and other station programs (1701 through 1807). It is also corrected in software version 03.10.12.

Central Office Calls, Placing

Out-Of-Range Data While Programming Trunk Group Access

The following Trunk Group Access Out-Of-Range data programming entry error is corrected in software version 03.10.12. This problem occurred in version 03.10.08.

1. Enter program **1804-Extension Trunk Group Access**.
2. Press **HOLD**.
3. Dial 0, then press **Vol Down**. You see: **255** (even though the entry range is 90-98).

DS1000 03.10.12 Release Notes

Software Corrections in 03.10.12

Directory Dialing

Unlisted Name Does Not Display Correctly

When using Directory Dialing, if an extension user selects a letter for which there is no corresponding name, the display shows: **UNLISTED NAME**. In software version 03.10.08, the display would show a single corrupted character instead. This is corrected in software version 03.10.12.

Distinctive Ringing

ASSIGN Soft Key Not Displayed

In software version 03.10.08, the **ASSIGN (ASGN)** soft key would not display if an extension had **0101-Extension Ring Override** enabled in their Class of Service. In version 03.10.12, the **ASSIGN (ASGN)** soft key displays correctly.

IntraMail

Improved Fax Detection Compatibility

The system's DSP code has been modified to accept a broader band of acceptable CNG tones. This makes IntraMail Fax Detection compatible with a wider variety of fax machines.

Names For Extensions And Trunks

Pressing LND Blanks Out Entire Name

Software version 03.10.12 corrects a problem in version 03.10.08 in which pressing **LND** while reprogramming a name would blank out the entire name. In version 03.10.08, the following would occur:

1. With a name already programmed,
At a Super Display Telephone, press **PROGRAM + NAME** .
At a 22- or 34-Button Display Telephone, press **PGM + MORE + MORE + NAME**.
2. Press **Vol Down** to go to the first character position.
3. Press **LND**. The entire name blanks out.

In software version 03.10.12, pressing **LND** while the cursor is over the first character position does nothing.

PC Program

Occasional Reset During Logon

Software version 03.10.12 corrects a problem in prior 03.**.** versions in which connecting to the system using the PC Program would occasionally cause the system to reset.

DS1000 03.10.12 Release Notes

Software Corrections in 03.10.12

System Diagnostics

Out-Of-Range Data Entry Problem While Resetting Extension Ports

Program **9901-Reset Station Port** allows you to reset telephone extensions (300-333 in DS1000, 300-427 in DS2000) and IntraMail/UltraMail voice mail extensions (500-507). In prior 03.**.** versions, the program also inadvertently allowed you to reset Ring Group (600-607) and UCD Hunting Group (700-707) master numbers. This is corrected in version 03.10.12.

DS1000 03.10.12 Release Notes

Software Corrections in 03.10.12

DS100003.11.00 Release Notes

New Features in 03.11.00

There are no New Features in this release.

DS1000 03.11.00 Release Notes

Enhanced Features in 03.11.00

Extension Ringdown

Ringdown to Speed Dial Numbers

The Extension Ringdown destination can be an extension, the Voice Mail master number (e.g., 700), a Ring Group master number, a UCD Group master number, or a System Speed Dial bin (#200-299). This capability was always available from telephone programming. When using the PC Program to set up Extension Ringdown, you must use system software version 03.11.00 and PC Program version 01.01.07 or higher.

Selectable Display Messaging

Message Scrolling Operation Changed

The sequence of steps that allows a user to scroll through and select a Selectable Display Messaging choices is changed in software version 03.11.00.

To select a Selectable Display Message:

1. Press **ICM** and dial ***38**.
You can also use your Soft Keys to enable Selectable Display Messaging.
2. Enter the number of the message you want to select.
OR
Press **Vol Up** and **Vol Down** to scroll through the available message numbers.
3. Press **HOLD** to select the message.
4. Press **Vol Up** and **Vol Down** to scroll through the text of the available messages.
OR
Press **HOLD** to program or append the message text.
5. Press **HOLD**.

DS1000 03.11.00 Release Notes

Software Corrections in 03.11.00

IntraMail

Conversation Record Limit Resets System

Software version 03.11.00 corrects a problem in prior 03.**.** versions in which a Conversation Record in progress when the recording limit was reached would reset the system. This no longer occurs. Note that the Conversation Record limit is 10 times the setting of *8004: IntraMail System Options: Subscriber Message Length*.

MW Lamp Goes Out On Quick Hangup

In software versions prior to 03.11.00, a user with new messages could call their mailbox, quickly hang up, and have the MW LED inadvertently go out (without listening to the messages). This problem is fixed in version 03.11.00.

Pressing L (5) Quickly Can Lock Up Mailbox

In prior 03.**.** software versions, when a user with multiple messages in their mailbox press L quickly to listen to their messages, the Voice Mail port could lock up. IntraMail would not respond for that user. The port would clear itself after a minute or so, or would clear when the user hung up. This problem is fixed in software version 03.11.00.

UTRF To 0 May Reset System

The following scenario could cause a system reset in versions 03.**.** prior to 03.11.00:

1. Set up a Key Ring trunk to overflow to Voice Mail.
2. When a call rings in and is unanswered, it overflows to Voice Mail.
3. The caller fails to dial, and the trunk follows the Timeout action in the active Dial Action Table (which is UTRF to 0).
4. As the call rings the Call Queue key at the busy operator, the outside party hangs up.
5. The operator answers the call and then dials # to disconnect the call using Forced Trunk Disconnect.
6. If the operator then presses the Call Queue + **SPK**, the system will reset.

Language Selection

Additional Translation Corrections

Software version 03.11.00 contains numerous Spanish language corrections. These corrections only apply when **1807-Display Language** = 1 (Spanish).

DS1000 03.11.00 Release Notes

Software Corrections in 03.11.00

DS100003.12.00 Release Notes

New Features in 03.12.00

There are no New Features in this release.

DS1000 03.12.00 Release Notes

Enhanced Features in 03.12.00

Ringdown Extension

Ringdown to Personal Speed Dial Bin

When programming a ringdown destination in **1802-Ring Down Destination**, optionally enter #701-#720 to have the destination be an extension's Personal Speed Dial bin. In prior software versions, ring down to a Personal Speed Dial bin was not available.

IntraMail

Screened Transfer Recall Loses Queue Elements

If a Screened Transfer (TRF) from the Automated Attendant is unanswered, in prior 03.**.** software versions the system could lose queue elements. This could cause system misoperation. Queue elements would not be restored until the system was reset. This is corrected in software version 03.12.00.

Message Notification Voice Activity Detector Improved

Software version 03.12.00 implements new DSP code which improves the Message Notification Voice Activity Detector. During a Message Notification callout, this detector senses when the far end has answered and the called party speaks. In software version 03.10.12, the Voice Activity Detector was inadvertently degraded when the IntraMail Fax Detection was enhanced.

Selectable Display Messaging

Cannot Enter Text For Blank Messages

After selecting a blank message (message 10-15), the user can enter message text of their choosing (up to 20 characters). In software versions 03.10.** and 03.11.00, the user could not enter text for messages 10-15.

Station Message Detail Recording

Abbreviated Caller ID Messages

Software version 03.12.00 corrects the following errors on the SMDR report for Caller ID:

- **OUT** now displays as **OUT OF AREA**
- **PRIV** now displays as **PRIVATE**

DS1000 03.12.00 Release Notes

Software Corrections in 03.12.00

DS100003.14.00 Release Notes

New Features in 03.14.00

There are no New Features in this release.

DS1000 03.14.00 Release Notes

Enhanced Features in 03.14.00

There are no Enhanced Features in this release.

Account Codes

Account Code/Single Line Problems With MFC Dialing

Various Account Code problems with single line ports and MFC dialing are corrected in software version 03.14.00. These issues do not apply to North American installations.

IntraMail

Dialing 9 While Leaving A Message Provides Incorrect Voice Prompt

In prior software versions, dialing 9 consecutively to abort leaving a message would cause an incorrect voice prompt. After dialing 9 once, the caller would hear, *“That message has not been sent.”* After dialing the second 9, the caller would hear, *“That message has been sent.”* The message was not sent; the voice prompt was incorrect. The incorrect voice prompt does not occur in software version 03.14.00.

Language Selection

Language Corrections for Toll Restriction

Software version 03.14.00 contains Spanish language text corrections for Toll Restriction (program series 0600). These corrections apply to both US Toll Restriction (when Spanish is the chosen language) and to Latin American Toll Restriction.

DS1000 03.14.00 Release Notes

Software Corrections in 03.14.00

NEC

NEC America, Inc., Corporate Networks Group
4 Forest Parkway, Shelton, CT 06484
Tel: 800-365-1928 Fax: 203-926-5458
cng.nec.com

Other Important Telephone Numbers

Sales:	203-926-5450
Customer Service:	203-926-5444
Customer Service FAX:	203-926-5454
Technical Service:	203-925-8801
Discontinued Product Service:	900-990-2541
Technical Training:	203-926-5430
Emergency Technical Service (After Hours)	203-929-7920
(Excludes discontinued products)	

NEC

NEC America, Inc., Corporate Networks Group
4 Forest Parkway, Shelton, CT 06484
TEL: 203-926-5400 FAX: 203-929-0535
cng.nec.com

80200RNT35
80200RNT35

February 27, 2004
Printed in U.S.A.